STORMWATER MANAGEMENT REPORT

3501 STATE ROUTE 66 REDEVELOPMENT

3501 STATE ROUTE 66

BLOCK No. 3903, LOT No. 12 & 13

TOWNSHIP OF NEPTUNE, MONMOUTH COUNTY, NEW JERSEY

Prepared For:

3501 RT 66 LLC

4488 W Boy Scout Boulevard, Suite 250

Tampa, Florida 33607

Prepared By:

Langan Engineering & Environmental Services, LLC

300 Kimball Drive

Parsippany, New Jersey 07054

NJ Certificate of Authorization No: 24GA27996400

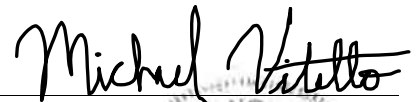

Michael Vitello, P.E.



John Cote, P.E.

New Jersey Professional Engineer Lic. No. 24GE03705800

Revised May 3, 2024

Revised July 28, 2023

Revised May 10, 2023

August 26, 2022

100775002

LANGAN

TABLE OF CONTENTS

EXECUTIVE SUMMARY	1
1.0 INTRODUCTION	1
2.0 PROJECT DESCRIPTION	2
2.1 EXISTING SITE DESCRIPTION.....	2
2.2 SUBSURFACE CONDITIONS.....	2
2.3 FLOOD HAZARD AREA	2
2.4 PROPOSED DEVELOPMENT.....	3
3.0 STORMWATER MANAGEMENT	4
3.1 STORMWATER QUANTITY DESIGN.....	4
3.1.1 Design Criteria	4
3.1.2 Design Methodology	5
3.1.3 Points of Analysis	6
3.1.4 Existing Watersheds	7
3.1.5 Allowable Peak Discharges	8
3.1.6 Proposed Watersheds	12
3.1.7 Proposed Detention Routing	15
3.1.8 Quantity Control BMP Design Summary	17
3.1.9 Stormwater Quantity Summary	19
3.2 STORMWATER QUALITY DESIGN.....	21
3.2.1 Design Criteria	21
3.2.2 Design Methodology	21
3.2.3 Design Summary.....	22
3.2.4 Trash and Waste	22
3.3 GROUNDWATER RECHARGE	22
3.3.1 Design Criteria	22
3.3.2 Design Methodology	23
3.3.3 BMP Design	23
3.3.4 Design Summary.....	24
3.4 NON-STRUCTURAL STORMWATER MANAGEMENT STRATEGIES.....	25
3.5 STORMWATER CONVEYANCE DESIGN.....	25
3.5.1 Design Criteria	25
3.5.2 Design Methodology	25
4.0 SOIL EROSION AND SEDIMENT CONTROL	26
5.0 STORMWATER MAINTENANCE PLAN	26
6.0 CONCLUSION	26
7.0 REFERENCES	27

LIST OF FIGURES

FIGURE	DESCRIPTION
1	Site Location Map
2	FEMA Flood Insurance Rate Map
3	Soils Map
4	Existing Watershed Map
5	Proposed Watershed Map
6	Proposed Drainage Subarea Map
7	Water Quality Drainage Area Map
8	Existing Regulated Motor Vehicle Surface Map
9	Proposed Regulated Motor Vehicle Surface Map
10	NJDOT Swale Watershed Map

LIST OF DRAWINGS

DRAWING	DESCRIPTION
CG100	Master Grading Plan
CG101	Partial Grading Plan
CG102	Partial Grading Plan
CG103	Master Drainage Plan
CG104	Partial Drainage Plan
CG105	Partial Drainage Plan
CG501	Drainage Details
CG502	Drainage Details

LIST OF APPENDICES

APPENDIX	DESCRIPTION
A	Existing Stormwater Discharge Calculations
B	Proposed Stormwater Discharge Calculations
C	Pond Routing Calculations
D	Stormwater Conveyance Calculations
E	Stormwater Quality & Groundwater Recharge Calculations
F	Low Impact Development Checklist
G	Geotechnical Investigation Information

EXECUTIVE SUMMARY

The proposed stormwater management and conveyance systems for the proposed 3501 State Route 66 Redevelopment project have been designed in accordance with the New Jersey Department of Environmental Protection stormwater rules (NJAC 7:8), the New Jersey Department of Transportation drainage design guidelines, and the Township of Neptune stormwater regulations.

The proposed redevelopment includes the construction of:

- A 251,022± square foot warehouse with 32 loading docks and 25 trailer parking spaces;
- A 15,000 square foot retail building with an open space amenity area; and,
- Associated driveways, sidewalks, car parking areas, stormwater and utility infrastructure, and landscaping.

The proposed redevelopment increases regulated motor vehicle surfaces by more than one-quarter acre and disturbs more than one acre of land; therefore, this project is considered a “major development” from a stormwater management perspective, and the proposed design is required to address stormwater quantity, quality, and groundwater recharge requirements. The proposed stormwater management system consists of the following:

- A subsurface conveyance system consisting of inlets, manholes, and pipes to convey stormwater runoff from the 25-year design storm event;
- 4 small-scale bioretention basins;
- 2 small-scale infiltration basins;
- 1 large-scale infiltration basin; and,
- 1 porous asphalt pavement system.

By using the stormwater management measures identified above and reviewing the results of the detailed calculations provided in this report, the stormwater management design is in accordance with the Township of Neptune, NJDOT, and NJDEP stormwater rules, regulations, and ordinance requirements in effect at the time of the preparation of this report.

1.0 INTRODUCTION

This report addresses the engineering design of the stormwater conveyance and management system for the proposed redevelopment of a former office complex at 3501 State Route 66 in Neptune Township, New Jersey. The proposed stormwater management system is designed in accordance with:

- New Jersey Department of Environmental Protection (NJDEP) stormwater rules (NJAC 7:8);
- New Jersey Standards for Soil Erosion and Sediment Control;
- New Jersey Department of Transportation Roadway Design Manual; and
- Township of Neptune Ordinance No. 21-07 – Township Stormwater Management Ordinance, Section 528 of the Land Development Ordinance

2.0 PROJECT DESCRIPTION

2.1 Existing Site Description

The project site is comprised of Block No. 3903, Lot No. 12 & 13 in the Township of Neptune, Monmouth County, New Jersey. The 47.38± acre tract consists of a vacant office complex, parking areas, and wetlands, and is bound by vacant land and industrial properties to the north, Green Grove Road to the east, State Route 66 to the south, and an office and industrial complex to the west; refer to Figure 1 – Site Location Map. Jumping Brook traverses the western portion of the property, flowing from north to south toward State Route 66.

The site topography generally slopes from northeast to southwest, predominantly toward Jumping Brook, with approximately 50 feet of grade change occurring across the site. Slopes within the site vary from generally 2% to as steep as approximately 50% along steeper embankments. The majority of existing stormwater runoff generated from the subject site is conveyed via existing conveyance networks toward Jumping Brook. The stormwater runoff generated from the southeastern portion of the tract is conveyed via an existing conveyance network southward across State Route 66 to Betty Brook, which is a tributary to Jumping Brook.

2.2 Subsurface Conditions

According to the Natural Resources Conservation Service (NRCS) Web Soil Survey, the underlying soils in the project area consist primarily of Atsion sand, Downer-urban land complex, and Evesboro-urban land complex, with smaller areas of other soil types. Soils are assumed to have a hydrologic soil group classification of “A” or “D,” depending on the presence of wetlands, an indicator of a high groundwater table – refer to Figure 3 – Soils Map.

2.3 Flood Hazard Area

Based on a review of the Federal Emergency Management Agency (FEMA) Flood Insurance Rate

Map (FIRM) for Monmouth County, Map #34025C0327F, dated effective September 25, 2009, the subject property is located within a 100-year fluvial flood hazard area; refer to Figure 2 – FEMA Flood Insurance Rate Map. On FEMA flood mapping, Jumping Brook is referred to as Jumping Brook 2, in order to distinguish it from another stream of the same name (Jumping Brook 1) that is also located in Monmouth County.

According to Flood Profile 73P for Jumping Brook 2, located in the Flood Insurance Study Volume 2 of 3 for Monmouth County, New Jersey, dated effective September 25, 2009, the 100-year flood hazard elevation across the subject tract, between cross sections AD and AF, is EL. 71.4 (NAVD 88).

The NJDEP has also conducted a flood study on Jumping Brook. According to a plan numbered Plate 24, titled “Jumping Brook – Supplemental Flood Hazard Studies & Mapping – Neptune Township – Monmouth County, Sta. 173+00 to Sta. 212+16,” the 100-year flood hazard elevation across the subject tract, between cross sections AC and AE, is EL. 65.00 (NGVD 29), and the New Jersey Flood Hazard Area Design Flood (NJFHADF) elevation is EL. 66.50 (NGVD 29).

In accordance with N.J.A.C 7:13-3.2.(c), where a department (NJDEP) delineation for a regulated water has been promulgated prior to January 24, 2013, the applicant shall utilize whichever results in a higher flood hazard area design flood elevation between Method 1, the department (NJDEP) delineation, or Method 2 in tidal flood hazard areas or Method 3 in fluvial flood hazard areas. According to N.J.A.C. 7:13-3.4.(e).1, under Method 3 (FEMA Fluvial Method), the flood hazard area design flood elevation shall be equal to one foot above the FEMA 100-year flood elevation, which results in the NJFHADF for the subject tract being EL. 72.4 (NAVD 88). This elevation is significantly higher than the Method 1 NJFHADF elevation, and is therefore the elevation that governs.

2.4 Proposed Development

The proposed redevelopment at the project site will consist of the following improvements:

- A 251,022± square foot warehouse with 32 loading docks and 25 trailer parking spaces;
- A 15,000 square foot retail building;
- An open space amenity area;
- Associated driveways, sidewalks, car parking areas, utility infrastructure, and landscaping; and,
- A stormwater management system consisting of 4 small-scale bioretention basins, 2 small-scale infiltration basins, 1 large-scale infiltration basin, 1 porous asphalt pavement system, and a subsurface conveyance network comprised of inlets, pipes, and manholes.

3.0 STORMWATER MANAGEMENT

The proposed redevelopment disturbs over 1 acre of land and increases regulated motor vehicle surface by more than one-quarter acre; therefore, this project is considered a major development as defined by the NJDEP stormwater rules (NJAC 7:8). Projects that qualify as major developments are required to design stormwater management systems that address:

- Stormwater quantity;
- Stormwater quality;
- Groundwater recharge; and,
- Nonstructural measures

The following sections provided additional detail regarding each of the stormwater design regulations.

3.1 Stormwater Quantity Design

3.1.1 Design Criteria

In accordance with N.J.A.C. 7:8-5.6.(b).3, stormwater management measures are to be designed so that the post-construction peak runoff rates for the 2-, 10-, and 100-year design storm events are 50, 75, and 80%, respectively, of the pre-construction runoff rates for the portion of the site on which the proposed development is to be constructed. The portions of the project site that are to remain undisturbed in the post-construction condition are not subject to rate control measures.

Alternatively, in accordance with N.J.A.C. 7:8-5.6.(b).1, it can be demonstrated through hydrologic and hydraulic analyses that the post-construction runoff hydrographs for the 2-, 10-, and 100-year design storm events do not exceed, at any point in time, the pre-construction runoff hydrographs for the same storm events.

The proposed redevelopment results in each point of analysis varying in terms of realizing an increase in post-construction peak runoff rates when compared to pre-construction peak runoff rates. Therefore, it shall be demonstrated in accordance with N.J.A.C. 7:8-5.6.(b).3 that the post-construction peak runoff rates for the 2-, 10-, and 100-year design storm events are 50, 75, and 80%, respectively, of the pre-construction runoff rates for the portion of the site on which the redevelopment is to take place and quantity control through the implementation of BMPs is required. For the points of analysis where there are no quantity control BMPs being implemented, and the total watershed area contributing to a point of analysis decreases in the

post-construction condition, it shall be demonstrated in accordance with N.J.A.C. 7:8-5.6.(b).1 that the post-construction runoff hydrographs for the 2-, 10-, and 100-year design storm events do not exceed, at any point in time, the pre-construction runoff hydrographs for the same storm events.

3.1.2 Design Methodology

This study was prepared utilizing the Natural Resources Conservation Service (NRCS - formerly SCS) method to analyze the pre- and post-development stormwater runoff rates and volumes. This methodology meets the NJDEP stormwater calculation requirements presented in Section 7:8 of the New Jersey Administrative Code (N.J.A.C.) recognizing existing conditions. Stormwater hydrographs were developed utilizing the NOAA Atlas 14 Region D 24-hour storm distribution, and precipitation depths are referenced from the NOAA Atlas 14, Volume 2, Version 3 Point Precipitation Frequency Estimates Table for Neptune Township, New Jersey, accessed on December 16, 2021, for the 2-, 10-, 25-, and 100-year return periods. The table below summarizes the rainfall event totals.

Table 1 – NOAA Atlas 14 Precipitation Summary for 24-Hour Storm Events			
2-yr (in)	10-yr (in)	25-yr (in)	100-yr (in)
3.49	5.40	6.74	9.24

A time of concentration was calculated for each watershed. The time of concentration is defined as the time for runoff to travel from the hydraulically most remote point of the watershed to the point of interest. Values of the time of concentration were determined for existing and proposed conditions based on land cover and slope of the flow path using methods described in TR-55 and Chapter 5 of the New Jersey Best Management Practices (BMP) Manual. A time of concentration calculation was performed for both the pervious and impervious land coverage areas within each watershed in order to more accurately model peak runoff rates. For the post-construction time of concentration calculations, the McCuen-Spiess limitation is applied to the sheet flow travel time portion of the calculation. Due to technical limitations of the hydrologic software used to develop hydrographs, the minimum time of concentration is 2 minutes.

A runoff curve number (CN) was selected based upon the land cover type and underlying soil hydrologic classification within each watershed. In accordance with Chapter 5 of the New Jersey BMP Manual, peak runoff rates are calculated for each individual land cover type within the watershed and then hydraulically added together to determine the peak runoff rate of the watershed, rather than using the weighted runoff curve number (CN) methodology. Runoff curve numbers are referenced from Tables 2-2a and 2-2c of TR-55: Urban Hydrology for Small

Watersheds.

3.1.3 Points of Analysis

All stormwater runoff generated from the project site eventually discharges into Jumping Brook or Betty Brook, a tributary to Jumping Brook.

Point of Analysis 1 (POA-1) refers to a location within Jumping Brook at an existing headwall structure in the southwestern portion of the subject property along State Route 66. Jumping Brook flows from north to south through the property, and enters this headwall structure, eventually flowing through a 10'-9"x7'-6" concrete box culvert that traverses State Route 66.

Point of Analysis 1A (POA-1A) refers to an existing headwall structure located in the southwestern portion of the project site, adjacent to State Route 66. Runoff is conveyed via an existing stormwater conveyance network to this headwall, directly discharging into Jumping Brook and POA-1. This point of analysis was chosen in order demonstrate for erosion control purposes that flow rates will not increase in the post-construction condition, thereby not increasing discharge velocities at the outfall.

Point of Analysis 1B (POA-1B) refers to an existing headwall structure located in the western portion of the project site. Runoff is conveyed via an existing stormwater conveyance network to this headwall, directly discharging into Jumping Brook and POA-1. This point of analysis was chosen in order to demonstrate for erosion control purposes that flow rates will not increase in the post-construction condition, thereby not increasing discharge velocities at the outfall.

Point of Analysis 2 (POA-2) refers to an existing inlet located within State Route 66, and represents the point far enough downstream within the NJDOT's existing conveyance network that captures all of the runoff generated by the project site. Runoff is conveyed via overland flow from the project site, into the right-of-way, and into the NJDOT's conveyance network. From this point, runoff is conveyed to Jumping Brook.

Point of Analysis 3 (POA-3) refers to the opening of an existing 8" clay pipe, located within the right-of-way just off of the southeastern portion of the project site. Runoff is conveyed via overland flow to this pipe opening, and from this point, runoff is conveyed via NJDOT's existing conveyance network southward, across State Route 66, and into Betty Brook, a tributary to Jumping Brook.

Point of Analysis 4 (POA-4) refers to the neighboring property abutting the northerly property line of the subject tract. Runoff is conveyed via overland flow onto this property and into yard drains, which ultimately discharge into Jumping Brook.

3.1.4 Existing Watersheds

The existing watersheds are depicted on Figure 4 – Existing Watershed Map.

Watershed EX-1A is approximately 10.34± acres and consists of portions of the existing building, parking areas, and landscape islands that are proposed to be disturbed in the post-construction condition. This watershed is conveyed via an existing conveyance network, ultimately discharging from a 27" diameter reinforced concrete pipe to Point of Analysis 1A (POA-1A) and Jumping Brook (POA-1).

Watershed EX-1B is approximately 4.90± acres and consists of portions of the existing building, parking areas, and landscape islands that are proposed to be disturbed in the post-construction condition. This watershed is conveyed via an existing conveyance network, ultimately discharging from a 42" diameter reinforced concrete pipe to Point of Analysis 1B (POA-1B) and Jumping Brook (POA-1).

Watershed EX-1C is approximately 1.50± acres and consists of primarily pervious grass and wooded areas that are proposed to be disturbed in the post-construction condition. This watershed is conveyed via overland flow to Jumping Brook (POA-1).

Watershed EX-1-UNDISTURBED is approximately 24.50± acres and consists of primarily wooded areas that are proposed to remain undisturbed in the post-construction condition. This watershed is conveyed via overland flow to Jumping Brook (POA-1).

Watershed EX-2 is approximately 3.90± acres and consists of existing woods, grass areas, and pavement areas in the southern portion of the subject property that are proposed to be disturbed in the post-construction condition. This watershed is conveyed primarily via overland flow to the State Route 66 right-of-way, where runoff is collected by the existing NJDOT conveyance network, ultimately discharging to Point of Analysis 2 (POA-2) and eventually Jumping Brook.

Watershed EX-3 is approximately 1.36± acres and consists of existing woods, grass areas, and pavement areas in the southeastern portion of the subject property. This watershed is conveyed primarily via overland flow to an existing wetland area, which discharges via an 8" diameter clay pipe within the State Route 66 right-of-way (POA-3). From this point, runoff is conveyed southward via the existing NJDOT conveyance network to Betty Brook, a tributary of Jumping Brook.

Watershed EX-3-UNDISTURBED is approximately 0.64± acres and consists of existing woods and grass areas in the southeastern portion of the subject property which are proposed to remain

undisturbed in the post-construction condition. This watershed is conveyed primarily via overland flow to an existing wetland area, which discharges via an 8" diameter clay pipe within the State Route 66 right-of-way (POA-3). From this point, runoff is conveyed southward via the existing NJDOT conveyance network to Betty Brook, a tributary of Jumping Brook.

Watershed EX-4 is approximately 0.62± acres and consists of existing woods, grass areas, and pavement areas in the northern portion of the subject property. This watershed is conveyed via overland flow to conveyance networks on the neighboring property (POA-4), before ultimately discharging to Jumping Brook.

A summary of the existing watershed characteristics and peak flows are presented in the table on the following page; refer to Appendix A for weighted curve number (CN) calculation worksheets and supporting hydrologic calculations.

Table 2 – Summary of Existing Peak Discharges			
Watershed	2-yr Storm Event Peak Flow (CFS)	10-yr Storm Event Peak Flow (CFS)	100-yr Storm Event Peak Flow (CFS)
EX-1A	19.47	30.31	55.03
EX-1B	11.33	17.64	31.46
EX-1C	0.11	0.17	0.85
EX-1-UNDISTURBED	30.86	48.05	86.50
EX-2	0.99	1.54	3.29
EX-3	0.12	0.19	0.92
EX-3-UNDISTURBED	0.00	0.00	0.17
EX-4	0.14	0.21	0.47

3.1.5 Allowable Peak Discharges

The proposed redevelopment increases the amount of impervious coverage compared to the existing condition, causing post-construction peak runoff rates to exceed pre-construction peak runoff rates within the watersheds with the most concentrated areas of development. Therefore, it shall be demonstrated in accordance with N.J.A.C. 7:8-5.6.(b).3 that the post-construction peak runoff rates for the 2-, 10-, and 100-year design storm events are 50, 75, and 80%, respectively, of the pre-construction runoff rates for the portions of the site on which the proposed development is to be constructed and quantity control BMPs are required to be implemented.

For the points of analysis where there are no quantity control BMPs being implemented and the total watershed area contributing to a point of analysis decreases, it shall be demonstrated in accordance with N.J.A.C. 7:8-5.6.(b).1 that the post-construction runoff hydrographs for the 2-, 10-, and 100-year design storm events do not exceed, at any point in time, the pre-construction

runoff hydrographs for the same storm events.

Watersheds noted as being “disturbed” in the watershed descriptions in Section 3.1.4 of this report represent the areas on the project site that are to be disturbed as part of the proposed redevelopment and are therefore subject to post-construction peak rate reductions if post-construction peak runoff rates exceed pre-construction peak runoff rates and quantity control BMP’s are required to be implemented.

Watersheds noted as being “undisturbed” in the watershed descriptions in Section 3.1.4 of this report represent the areas on the project site that are to remain undisturbed as part of the proposed redevelopment and are therefore not subject to peak rate reductions.

The following section summarizes the quantity control criteria being established for each point of analysis, which watersheds are subject to peak rate reductions, and the allowable peak discharges for each point of analysis.

- Point of Analysis 1A (POA-1A): This point of analysis was chosen in order to demonstrate for erosion control purposes that flow rates will not increase in the post-construction condition, thereby not increasing discharge velocities at the outfall of the existing 27” diameter reinforced concrete pipe. Therefore, it shall be demonstrated in accordance with N.J.A.C. 7:8-5.6.(b).1 that the post-construction runoff hydrographs for the 2-, 10-, and 100-year design storm events do not exceed, at any point in time, the pre-construction runoff hydrographs for the same storm events. The watershed contributing to this point of analysis, EX-1A, ultimately contributes to Point of Analysis 1 (POA-1). Refer to the Point of Analysis 1 (POA-1) allowable discharge summary.

Table 3 – POA-1A Allowable Peak Discharges		
Design Storm Event	Existing Peak Discharge (CFS)	Allowable Peak Discharge (CFS)
2-Year	19.47	19.47
10-Year	30.31	30.31
100-Year	55.03	55.03

Note: Total Allowable Peak Discharges are calculated by hydraulically adding runoff hydrographs and may not reflect the direct addition of peak discharge rates. Refer to the hydrograph report calculations in Appendix A.

- Point of Analysis 1B (POA-1B): This point of analysis was chosen in order to demonstrate for erosion control purposes that flow rates will not increase in the post-construction condition, thereby not increasing discharge velocities at the outfall of the existing 42”

diameter reinforced concrete pipe. Therefore, it shall be demonstrated in accordance with N.J.A.C. 7:8-5.6.(b).1 that the post-construction runoff hydrographs for the 2-, 10-, and 100-year design storm events do not exceed, at any point in time, the pre-construction runoff hydrographs for the same storm events. The watershed contributing to this point of analysis, EX-1B, ultimately contributes to Point of Analysis 1 (POA-1). Refer to the Point of Analysis 1 (POA-1) allowable discharge summary.

Table 4 – POA-1B Allowable Peak Discharges		
Design Storm Event	Existing Peak Discharge (CFS)	Allowable Peak Discharge (CFS)
2-Year	11.33	11.33
10-Year	17.64	17.64
100-Year	31.46	31.46

Note: Total Allowable Peak Discharges are calculated by hydraulically adding runoff hydrographs and may not reflect the direct addition of peak discharge rates. Refer to the hydrograph report calculations in Appendix A.

- Point of Analysis 1 (POA-1): The proposed redevelopment within this watershed results in peak runoff rates increasing in the proposed condition, and quantity control BMPs are required to be implemented. Therefore, it shall be demonstrated in accordance with N.J.A.C. 7:8-5.6.(b).3 that the post-construction peak runoff rates for the 2-, 10-, and 100-year design storm events are 50, 75, and 80%, respectively, of the pre-construction runoff rates for the disturbed portions of the overall watershed.

Table 5 – Watershed EX-1-DISTURBED Allowable Peak Discharges			
Design Storm Event	Existing Peak Discharge (CFS)	Allowable Discharge (%)	Allowable Peak Discharge (CFS)
2-Year	30.86	50%	15.43
10-Year	48.05	75%	36.03
100-Year	86.50	80%	69.20

Note: Watershed EX-1-DISTURBED is the resultant combined watershed after hydraulically adding the disturbed watersheds that are subject to peak rate reductions that contribute to POA-1. These watersheds include watershed EX-1A, watershed EX-1B, and watershed EX-1C. Total existing peak discharges are calculated by hydraulically adding runoff hydrographs and may not reflect the direct addition of peak discharge rates. Refer to the hydrograph report calculations in Appendix A.

Table 6 – POA-1 Allowable Peak Discharges		
Design Storm Event	Existing Peak Discharge (CFS)	Allowable Peak Discharge (CFS)
2-Year	30.86	15.43
10-Year	48.05	36.03
100-Year	86.67	69.37

Note: Total Allowable Peak Discharges are calculated by hydraulically adding runoff hydrographs and may not reflect the direct addition of peak discharge rates. Refer to the hydrograph report calculations in Appendix A.

- Point of Analysis 2 (POA-2): The total contributing watershed area, including impervious area, is being reduced in the post-construction condition. Therefore, it shall be demonstrated in accordance with N.J.A.C. 7:8-5.6.(b).1 that the post-construction runoff hydrographs for the 2-, 10-, and 100-year design storm events do not exceed, at any point in time, the pre-construction runoff hydrographs for the same storm events.

Table 7 – POA-2 Allowable Peak Discharges		
Design Storm Event	Existing Peak Discharge (CFS)	Allowable Peak Discharge (CFS)
2-Year	0.99	0.99
10-Year	1.54	1.54
100-Year	3.29	3.29

Note: Total Allowable Peak Discharges are calculated by hydraulically adding runoff hydrographs and may not reflect the direct addition of peak discharge rates. Refer to the hydrograph report calculations in Appendix A.

- Point of Analysis 3 (POA-3): The total contributing watershed area, including impervious area, is being reduced in the post-construction condition. Therefore, it shall be demonstrated in accordance with N.J.A.C. 7:8-5.6.(b).1 that the post-construction runoff hydrographs for the 2-, 10-, and 100-year design storm events do not exceed, at any point in time, the pre-construction runoff hydrographs for the same storm events.

Table 8 – POA-3 Allowable Peak Discharges		
Design Storm Event	Existing Peak Discharge (CFS)	Allowable Peak Discharge (CFS)
2-Year	0.12	0.12
10-Year	0.19	0.19
100-Year	1.09	1.09

Note: Total Allowable Peak Discharges are calculated by hydraulically adding runoff hydrographs and may not reflect the direct addition of peak discharge rates. Refer to the hydrograph report calculations in Appendix A.

- Point of Analysis 4 (POA-4): The total contributing watershed area, including impervious area, is being reduced in the post-construction condition. Therefore, it shall be demonstrated in accordance with N.J.A.C. 7:8-5.6.(b).1 that the post-construction runoff hydrographs for the 2-, 10-, and 100-year design storm events do not exceed, at any point in time, the pre-construction runoff hydrographs for the same storm events.

Table 9 – POA-4 Allowable Peak Discharges		
Design Storm Event	Existing Peak Discharge (CFS)	Allowable Peak Discharge (CFS)
2-Year	0.14	0.14
10-Year	0.21	0.21
100-Year	0.47	0.47

Note: Total Allowable Peak Discharges are calculated by hydraulically adding runoff hydrographs and may not reflect the direct addition of peak discharge rates. Refer to the hydrograph report calculations in Appendix A.

3.1.6 Proposed Watersheds

The proposed watersheds are depicted on Figure 5 – Proposed Watershed Map.

Watershed PR-1A is approximately 2.80± acres and consists of portions of the proposed loading dock area, warehouse car parking area, and pervious landscape areas. Stormwater runoff is conveyed via overland flow and a proposed subsurface conveyance system to Small-Scale Infiltration Basin 1A (SSIB-1A). The watershed is then ultimately conveyed to POA-1B, prior to discharging to POA-1.

Watershed PR-1B is approximately 2.68± acres and consists of portions of the proposed warehouse roof area, car parking area, and pervious landscape areas. Stormwater runoff is conveyed via overland flow and a proposed subsurface conveyance system to Small-Scale

Bioretention Basin 1B (SSBB-1B). The watershed is then ultimately conveyed to POA-1B, prior to discharging to POA-1.

Watershed PR-1D is approximately 1.34± acres and consists of portions of the proposed warehouse roof area, drive aisles, and pervious landscape areas. Stormwater runoff is conveyed via overland flow and a proposed subsurface conveyance system to Small-Scale Infiltration Basin 1D (SSIB-1D). The watershed is then ultimately conveyed to POA-1B, prior to discharging to POA-1.

Watershed PR-1E is approximately 0.86± acres and consists of portions of the proposed warehouse roof area, drive aisles, and pervious landscape areas. Stormwater runoff is conveyed via overland flow and a proposed subsurface conveyance system to Small-Scale Bioretention Basin 1E (SSBB-1E). The watershed is then ultimately conveyed to POA-1B, prior to discharging to POA-1.

Watershed PR-1F is approximately 0.77± acres and consists of portions of impervious drive aisles and pervious landscape areas. Stormwater runoff is conveyed via overland flow and a proposed subsurface conveyance system to Small-Scale Bioretention Basin 1F (SSBB-1F). The watershed is then ultimately conveyed to POA-1B, prior to discharging to POA-1.

Watershed PR-1G is approximately 2.50± acres and consists of portions of the warehouse loading area and pervious landscape areas. Stormwater runoff is conveyed via overland flow and a proposed subsurface conveyance system to Small-Scale Bioretention Basin 1G (SSBB-1G). The watershed is then ultimately conveyed to POA-1B, prior to discharging to POA-1.

Watershed PR-1H is approximately 5.63± acres and consists of portions of the warehouse roof area and pervious landscape areas. Stormwater runoff is conveyed via overland flow and a proposed subsurface conveyance system to Large-Scale Infiltration Basin 1H (LSIB-1H). The watershed is then ultimately conveyed to POA-1B, prior to discharging to POA-1.

Watershed PR-1I is approximately 3.35± acres and consists of the retail building, parking areas, driveways, and pervious landscape areas. Stormwater runoff is conveyed via overland flow and a proposed subsurface conveyance system to an existing subsurface system, which conveys runoff to POA-1A, prior to discharging to POA-1.

Watershed PR-1J is approximately 0.67± acres and consists of pervious landscape areas. Stormwater runoff is conveyed via overland flow to Jumping Brook (POA-1).

Watershed PR-1K is approximately 0.46± acres and consists of parking areas and pervious

landscape areas. Stormwater runoff is conveyed via overland flow to Porous Asphalt Pavement System 1. This BMP then conveys runoff to POA-1A, prior to discharging to POA-1.

Watershed PR-1-UNDISTURBED is approximately 24.50± acres and consists of primarily wooded areas that are proposed to remain undisturbed in the post-construction condition. This watershed is conveyed via overland flow to Jumping Brook (POA-1).

Watershed PR-2 is approximately 1.09± acres and consists of the main entrance driveways from Route 66 that service the project site, and pervious landscape areas both onsite and within the right-of-way. This watershed is conveyed via overland flow and a proposed subsurface conveyance system to the NJDOT's existing conveyance network within Route 66. Runoff is then conveyed to POA-2, ultimately discharging into Jumping Brook.

Watershed PR-3 is approximately 0.33± acres and consists of a portion of the proposed driveway and pervious landscape areas. Stormwater runoff is conveyed via overland flow to POA-3, which ultimately discharges to Betty Brook.

Watershed PR-3-UNDISTURBED is approximately 0.64± acres and consists of grassed areas and wooded areas that are proposed to remain undisturbed in the post-construction condition. Stormwater runoff is conveyed via overland flow to POA-3, which ultimately discharges to Betty Brook.

Watershed PR-4 is approximately 0.13± acres and consists of pervious landscape areas. Stormwater runoff is conveyed via overland flow to POA-4, which ultimately discharges to Jumping Brook.

A summary of the existing watershed characteristics and peak flows are presented in the table below; refer to Appendix B for runoff curve number (CN) calculation worksheets and supporting hydrologic calculations.

Table 10 – Summary of Proposed Peak Discharges				
Watershed	2-yr Storm Peak Flow (CFS)	10-yr Storm Peak Flow (CFS)	25-yr Storm Peak Flow (CFS)	100-yr Storm Peak Flow (CFS)
PR-1A	5.70	8.86	11.23	16.49
PR-1B	4.47	6.95	9.06	14.11
PR-1D	2.32	3.61	4.58	6.83
PR-1E	1.94	3.02	3.86	5.65
PR-1F	1.30	2.02	2.62	4.08
PR-1G	6.98	10.87	13.69	19.36
PR-1H	14.87	23.14	29.25	41.55
PR-1I	7.55	11.75	14.79	21.18
PR-1J	0.00	0.04	0.13	0.50
PR-1K	1.47	2.28	2.86	3.96
PR-1-UNDISTURBED	0.00	0.10	0.51	4.62
PR-2	0.72	1.11	1.48	2.76
PR-3	0.12	0.19	0.27	0.61
PR-3-UNDISTURBED	0.00	0.00	0.01	0.17
PR-4	0.00	0.01	0.06	0.24

3.1.7 Proposed Detention Routing

Two small-scale infiltration basins, 4 small-scale bioretention basins, and 1 large-scale infiltration basin are proposed in order to meet the stormwater quantity requirements. According to N.J.A.C. 7:8-5.2.(f), small-scale infiltration basins and small-scale bioretention basins qualify as green infrastructure BMP's that may be utilized for stormwater quantity, stormwater runoff quality, and groundwater recharge without a waiver or variance, while large-scale infiltration basins qualify as green infrastructure BMP's that may be utilized for stormwater quantity without a waiver or variance.

Routing calculations have been provided in order to demonstrate that the basins have adequate storage capacity to safely convey storm events up to the 100-year design storm. Emergency spillway calculations have also been provided to demonstrate that there is a clear means of safely directing and passing the 100-year design storm event should there be a complete failure of the outlet control structure. The tables below summarize the 100-year storm event results for each BMP; refer to Appendix C for supporting calculations.

Table 11 – Summary of Small-Scale Infiltration Basin 1A					
Design Storm (YR)	Peak Inflow (CFS)	Peak Outflow (CFS)	Peak Water Surface EL. (FT)	Emergency Spillway EL. (FT)	Top of Berm EL. (FT)
100	16.49	2.01	91.49	92.50	94.00

Table 12 – Summary of Small-Scale Bioretention Basin 1B					
Design Storm (YR)	Peak Inflow (CFS)	Peak Outflow (CFS)	Peak Water Surface EL. (FT)	Emergency Spillway EL. (FT)	Top of Berm EL. (FT)
100	14.11	5.42	97.48	98.50	100.00

Table 13 – Summary of Small-Scale Infiltration Basin 1D					
Design Storm (YR)	Peak Inflow (CFS)	Peak Outflow (CFS)	Peak Water Surface EL. (FT)	Emergency Spillway EL. (FT)	Top of Berm EL. (FT)
100	6.83	6.44	92.57	93.67	95.00

Table 14 – Summary of Small-Scale Bioretention Basin 1E					
Design Storm (YR)	Peak Inflow (CFS)	Peak Outflow (CFS)	Peak Water Surface EL. (FT)	Emergency Spillway EL. (FT)	Top of Berm EL. (FT)
100	5.65	1.60	87.46	88.50	90.00

Table 15 – Summary of Small-Scale Bioretention Basin 1F					
Design Storm (YR)	Peak Inflow (CFS)	Peak Outflow (CFS)	Peak Water Surface EL. (FT)	Emergency Spillway EL. (FT)	Top of Berm EL. (FT)
100	4.08	0.51	88.47	90.00	91.25

Table 16 – Summary of Small-Scale Bioretention Basin 1G					
Design Storm (YR)	Peak Inflow (CFS)	Peak Outflow (CFS)	Peak Water Surface EL. (FT)	Emergency Spillway EL. (FT)	Top of Berm EL. (FT)
100	19.36	15.13	86.65	87.67	89.00

Table 17 – Summary of Large-Scale Infiltration Basin 1H					
Design Storm (YR)	Peak Inflow (CFS)	Peak Outflow (CFS)	Peak Water Surface EL. (FT)	Emergency Spillway EL. (FT)	Top of Berm EL. (FT)
100	41.55	3.84	87.69	89.50	91.00

The total proposed peak discharge rate for the point of analysis can then be calculated by adding together the peak outflow from the proposed small-scale bioretention basins, small-scale infiltration basins, and large-scale infiltration basin, along with the peak discharges from the

undetailed, undisturbed, and offsite watersheds.

Table 18 – Total Proposed Peak Discharges				
Point of Analysis	2-Year Storm	10-Year Storm	25-Year Storm	100-Year Storm
POA-1A	7.96	12.30	15.51	22.15
POA-1B	4.62	10.02	17.44	31.19
POA-1	12.14	21.45	31.32	52.47
POA-2	0.72	1.11	1.48	2.76
POA-3	0.12	0.19	0.27	0.68
POA-4	0.00	0.01	0.06	0.24

Note: Total Proposed Peak Discharges are calculated by hydraulically adding runoff hydrographs and may not reflect the direct addition of peak discharge rates. Refer to hydrograph report calculations in Appendix B.

3.1.8 Quantity Control BMP Design Summary

For small-scale infiltration basins, the following parameters must be met as part of the system design as per Chapter 9.8 of the New Jersey BMP Manual; all design criteria have been met – refer to calculations in the appendices of this report as well as the design drawings:

- Maximum contributory drainage area: 2.5 acres
- Minimum distance between basin bottom and seasonal high groundwater/bedrock: 2 feet
- Maximum water quality design storm event water depth: 24 inches
- Maximum design storm drain time: 72 hours

Exfiltration credit is not being taken for the design of the small-scale infiltration basins; therefore, pretreatment of stormwater runoff is not required.

For small-scale bioretention basins, the following parameters must be met as part of the system design as per Chapter 9.7 of the New Jersey BMP Manual; all design criteria have been met – refer to calculations in the appendices of this report as well as the design drawings:

- Maximum contributory drainage area: 2.5 acres
- Minimum distance between basin bottom and seasonal high groundwater/bedrock: 1 foot
- Maximum water quality design storm event water depth: 12 inches
- Maximum design storm drain time: 72 hours

The bioretention basins will be under-drained due to soils that are mostly unsuitable for infiltration

due to poor field-tested percolation test results of less than 1 inch per hour in various areas across the site.

For large-scale bioretention basins, the following parameters must be met as part of the system design as per Chapter 10.2 of the New Jersey BMP Manual; all design criteria have been met – refer to calculations in the appendices of this report as well as the design drawings:

- Minimum storage volume below first orifice: entire water quality design storm volume
- Minimum distance between basin bottom and seasonal high groundwater/bedrock: 2 feet
- Maximum design storm drain time: 72 hours

Per NJDEP stormwater rules, the large-scale infiltration basin is only being utilized to meet quantity control standards; although the basin is being design to meet applicable water quality standards, will provide groundwater recharge, and has been analyzed for groundwater mounding impacts, no water quality treatment or groundwater recharge volume credit are being taken for this BMP. Furthermore, per BMP Manual guidelines, exfiltration cannot be used in routing calculations.

The proposed porous pavement system consists of a porous asphalt surface course, a choker course that will filter pollutants, and an underlying stone storage bed subbase. The stone storage bed layer of the porous pavement system has been adequately sized to route the 100-year design storm event; therefore, there is more than adequate capacity to store the water quality storm event runoff volume, thus meeting the criteria to achieve 80% TSS removal. Each porous pavement system has been designed to meet the criteria set forth in Chapter 9.6 of the BMP Manual. The maximum area of additional inflow into each system is less than three times the bottom area of the system. Each porous pavement system will be designed with an underdrain, rather than infiltrate into the underlying soil; therefore, the minimum distance required between the bottom of the system and the groundwater table and bedrock is 1 foot per Chapter 9 of the BMP Manual. The underdrain systems have been sized so that the storage beds drain well under the maximum allowable 72 hour drawdown time. Refer to the sizing calculations located in Appendix E.

Table 19 – Proposed BMP Design Summary					
BMP	Contributory Drainage Area¹ (AC)	WQDS Water Depth (FT)	Test Pits & Borings²	Bottom of BMP EL.³	Groundwater or Mottling EL.
SSIB-1A	2.41	0.60	TP-1, B-1	88.50	76.0
SSBB-1B	2.40	0.95	B-2, B-3	91.25	82.0 ⁴
SSIB-1D	1.21	1.05	B-7, B-8	90.75	88.0
SSBB-1E	0.73	0.80	B-9, B-10	81.75	73.0
SSBB-1F	0.62	0.85	B-11, B-12	82.25	78.0
SSBB-1G	2.16	1.00	TP-3, B-19, B-20	80.25	77.0
LSIB-1H	4.71	0.80	B-21, B-22, B-23, B-24, B-25, B-26, B-27, B-28	83.50	78.0
Porous Asphalt System 1	0.46	N/A	B-15, B-16	85.25	81.0

Notes:

1. Contributory drainage area is the inflow drainage area to a BMP that excludes the area of the BMP itself.
2. Refer to the drainage plans, drawings CG103 through CG105, for test pit and boring locations. Refer to Appendix G for supporting geotechnical investigation information including test pit and boring logs.
3. The bottom of BMP elevation is either the bottom of the underdrain gravel layer for an under-drained bioretention basin or the bottom of the sand layer for infiltration basins.
4. If groundwater or soil mottling was not encountered, the depth of the deepest test pit or boring was assumed to be the groundwater elevation as a conservative measure.

3.1.9 Stormwater Quantity Summary

A summary for each point of analysis, detailing the existing, allowable, and proposed peak discharge rates, is outlined in the table below.

Table 20 – POA-1A Peak Discharge Summary			
Design Storm Event	POA-1A		
	Existing Peak Discharge (CFS)	Allowable Peak Discharge (CFS)	Proposed Peak Discharge (CFS)
2-Year	19.47	19.47	7.96
10-Year	30.31	30.31	12.30
100-Year	55.03	55.03	22.15

Table 21 – POA-1B Peak Discharge Summary			
Design Storm Event	POA-1B		
	Existing Peak Discharge (CFS)	Allowable Peak Discharge (CFS)	Proposed Peak Discharge (CFS)
2-Year	11.33	11.33	4.62
10-Year	17.64	17.64	10.02
100-Year	31.46	31.46	31.19

Table 22 – POA-1 Peak Discharge Summary			
Design Storm Event	POA-1		
	Existing Peak Discharge (CFS)	Allowable Peak Discharge (CFS)	Proposed Peak Discharge (CFS)
2-Year	30.86	15.43	12.14
10-Year	48.05	36.03	21.45
100-Year	86.67	69.37	52.47

Table 23 – POA-2 Peak Discharge Summary			
Design Storm Event	POA-2		
	Existing Peak Discharge (CFS)	Allowable Peak Discharge (CFS)	Proposed Peak Discharge (CFS)
2-Year	0.99	0.99	0.72
10-Year	1.54	1.54	1.11
100-Year	3.29	3.29	2.76

Table 24 – POA-3 Peak Discharge Summary			
Design Storm Event	POA-3		
	Existing Peak Discharge (CFS)	Allowable Peak Discharge (CFS)	Proposed Peak Discharge (CFS)
2-Year	0.12	0.12	0.12
10-Year	0.19	0.19	0.19
100-Year	1.09	1.09	0.68

Table 25 – POA-4 Peak Discharge Summary			
Design Storm Event	POA-4		
	Existing Peak Discharge (CFS)	Allowable Peak Discharge (CFS)	Proposed Peak Discharge (CFS)
2-Year	0.14	0.14	0.00
10-Year	0.21	0.21	0.01
100-Year	0.47	0.47	0.24

3.2 Stormwater Quality Design

3.2.1 Design Criteria

The project site is not subject to water quality treatment requirements as the development results in a decrease in regulated motor vehicle surface coverage. In accordance with N.J.A.C. 7:8-5.5.(a), major developments are subject to providing water quality treatment when the development results in an increase of one-quarter acre or more of regulated motor vehicle surface. In the existing condition, there are approximately 7.48± acres of regulated motor vehicle surface, and in the post-construction condition, there are approximately 6.93± acres of regulated motor vehicle surface; refer to Figure 8 – Existing Regulated Motor Vehicle Surface Map and Figure 9 – Proposed Regulated Motor Vehicle Surface map for delineations.

Although the project is not subject to providing water quality treatment, the stormwater BMPs for the project site must nevertheless be designed in accordance with the standards and regulations set forth in Chapter 9 of the BMP Manual and provide water quality treatment.

3.2.2 Design Methodology

The proposed stormwater quality BMPs that have been chosen for the project design consist of small-scale bioretention basins, small-scale infiltration basins, and a porous asphalt pavement system. Each of these BMPs achieves 80% TSS removal according to Chapter 9 of the BMP Manual.

The small-scale bioretention basins have been designed to achieve 80% TSS removal, meaning that they have been designed to store the entire water quality design storm event runoff volume below the first orifice opening of the outlet control structure, with the water surface elevation not exceeding 12 inches. The basins have been designed in an online configuration, and routing calculations have been provided for the 2-, 10-, and 100-year design storm events to show that the basins have been adequately sized to pass the larger design storm events safely through.

Each bioretention basin meets the criteria set forth in Chapter 9.7 of the BMP Manual for receiving TSS removal credit; refer to calculations in Appendix E.

The small-scale infiltration basins have also been designed to achieve 80% TSS removal, meaning that they have been designed to store the entire water quality design storm event runoff volume below the first orifice opening of the outlet control structures, with the water surface elevations not exceeding 24 inches. The basins meet the criteria set forth in Chapter 9.8 of the BMP Manual for receiving TSS removal credit; refer to calculations in Appendix E.

The porous asphalt pavement system has been designed to achieve 80% TSS removal, meaning that the inflow drainage area is less than three times the area of the porous asphalt, and that the stone storage bed has been adequately sized to store the volume of the water quality design storm event. The porous asphalt pavement system meets all of the design criteria set forth in Chapter 9.6 of the BMP Manual.

3.2.3 Design Summary

Although water quality treatment is not required for the project site, the small-scale bioretention basins, small-scale infiltration basins, and porous asphalt pavement system have all been designed in accordance with the design standards and regulations in the BMP Manual and provide 80% TSS removal water quality treatment.

3.2.4 Trash and Waste

Catch basins are proposed to have Type N Eco curb pieces to prevent trash and floatables from entering the proposed conveyance systems. The basin outlet control structures will also be fixed with trash racks to prevent debris and floatables from entering the downstream conveyance systems.

3.3 Groundwater Recharge

3.3.1 Design Criteria

The subject site is located within the Metropolitan Planning area PA-1 as defined by the New Jersey State Planning Area Map; however, portions of the project site are undeveloped, with wooded areas proposed to be removed in the post-construction condition. Therefore, per N.J.A.C. 7:8-5.4.(b).1.i, one hundred percent (100%) of the average annual pre-construction groundwater recharge volume for the disturbed area of the project site must be maintained in the post-construction condition.

3.3.2 Design Methodology

The groundwater recharge volume analysis has been performed using the NJDEP New Jersey Groundwater Recharge Spreadsheet (NJGRS), which is based on the data and computational procedures outlined in New Jersey Geological Survey Report GSR-32. The spreadsheet compares the pre-construction and post-construction land cover types within the property's native underlying soil classifications to develop the total annual recharge volume across the project site in both the pre-construction and post-construction conditions.

The post-development annual groundwater recharge deficit for the project site is calculated to be 224,832 cubic feet.

3.3.3 BMP Design

Small-Scale Infiltration Basin 1A and Small-Scale Infiltration Basin 1D have been designed to meet the recharge volume requirement for the project site.

The small-scale infiltration basins are designed with 6-inch thick sand bottoms. Test pits and infiltration tests performed within the basin footprint indicate that rock and groundwater are at a sufficient depth to enable infiltration. A summary of the test pit and infiltration test results are summarized below:

Table 26 – Small-Scale Infiltration Basin 1A Design Infiltration Rate Calculation			
Exploration	Permeability Test Result (in/hr)	Factor of Safety	Design Infiltration Rate (in/hr)
B-1	> 20	2	3.6
TP-1	7.2		

Table 27 – Small-Scale Infiltration Basin 1D Design Infiltration Rate Calculation			
Exploration	Permeability Test Result (in/hr)	Factor of Safety	Design Infiltration Rate (in/hr)
B-7	9.9	2	4.95
B-8	13.6		

Large-Scale Infiltration Basin 1H has been designed meet quantity control requirements for the project site and cannot be utilized in meeting the groundwater recharge requirement; however, it has been designed to infiltrate due to favorable subsurface conditions. Test pits and infiltration

tests performed within the basin footprint indicate that rock and groundwater are at a sufficient depth to enable infiltration. A summary of the test pit and infiltration test results are summarized below:

Table 28 – Large-Scale Infiltration Basin 1H Design Infiltration Rate Calculation			
Exploration	Permeability Test Result (in/hr)	Factor of Safety	Design Infiltration Rate (in/hr)
B-21	1.4	2	0.65
B-22	1.3		
B-24	1.4		
B-28	1.3		

A groundwater mounding analysis, utilizing the NJDEP Hantush Excel Spreadsheet, was performed for each infiltration BMP as outlined in Chapter 13 of the BMP Manual. Each basin has been designed so that the maximum groundwater mounding height occurs below the respective 6-inch thick sand layer; refer the basin design summary in the tables below. The maximum mounding height produced by the Hantush spreadsheet occurs at the geometric center of the basin, with lower mounding heights occurring at the perimeter.

Table 29 – Infiltration BMP Design Summary				
Infiltration Basin	Max. Groundwater Elevation	Bottom of BMP	Max. Mounding Height (FT)	Max. Mounding Elevation
SSIB-1A	76.0	88.50	3.80	79.80
SSIB-1D	88.0	90.75	2.71	90.71
LSIB-1H	78.0	83.50	5.41	83.41

Refer to supporting calculations for this entire analysis in Appendix E.

3.3.4 Design Summary

For the project site, the combined proposed annual post-construction groundwater recharge volume between Small-Scale Infiltration Basin 1A and Small-Scale Infiltration Basin 1D was calculated to be approximately 282,045 cubic feet, which exceeds the post-development annual groundwater recharge volume deficit of 224,832 cubic feet.

3.4 Non-Structural Stormwater Management Strategies

Nonstructural strategies were analyzed and implemented to the maximum extent practical for this project.

As per NJAC 7:8-5.3(b), there are nine nonstructural strategies:

1. Protect areas that provide water quality or are susceptible to erosion;
2. Minimize, break up and/or disconnect impervious surfaces;
3. Maximize protection of natural drainage features and vegetation;
4. Minimize decrease in time of concentration;
5. Minimize land disturbance, clearing and grading;
6. Minimize soil compaction;
7. Provide low maintenance vegetation;
8. Provide vegetated conveyance systems; and,
9. Provide pollutant source controls.

3.5 Stormwater Conveyance Design

3.5.1 Design Criteria

The on-site subsurface collection and conveyance system is designed to convey the 25-year design storm event. The conveyance systems conveying discharge from basins have been designed to convey the 100-year design storm event.

The proposed off-site subsurface collection and conveyance system within the NJDOT State Route 66 right-of-way is designed to convey the 25-year design storm event. The existing drainage swales within the right-of-way were also analyzed for capacity and stability, utilizing the 10-year design storm event per Table 10.2-C of the NJDOT Roadway Design Manual. Inlet spread calculations must be performed for all inlets which may have an effect on the NJDOT right-of-way. The inlet spread calculations analyze the spread of flow across roadways and driveways for the 10-year design storm event utilizing the minimum 10-minute duration rainfall intensity.

3.5.2 Design Methodology

The conveyance system was analyzed using the rational method for estimating runoff for the 25-year design storm event. The project site was divided into subareas based upon topography to determine the contributing runoff to each individual inlet or roof drain. Weighted runoff coefficients were calculated based upon the land cover type within each delineated sub-area. A runoff coefficient (C) was selected in accordance with Table 10-4: Recommended Coefficient of Runoff Values for Various Selected Land Uses from Section 10 of the 2015 New Jersey

Department of Transportation (NJDOT) Roadway Design Manual. Values of time of concentration were chosen based on land cover and slope of the flow path from the hydraulically most distant point in the subarea to the appropriate inlet. Unless otherwise specified, the minimum time of concentration used for each on-site inlet is 5 minutes. The minimum time of concentration used for each off-site inlet within the NJDOT right-of-way is 10 minutes per Section 10.3.5.C.1.e of the NJDOT Roadway Design Manual. Rainfall intensities were taken from the National Oceanic and Atmospheric Administration (NOAA) Precipitation Frequency Data Server for the project site; refer to Appendix D.

The proposed conveyance systems have been analyzed utilizing a starting tailwater elevation corresponding to the maximum design water elevation for the 25-year design storm event for the respective BMP that each conveyance network discharges into.

Detailed design calculations for the stormwater conveyance system are included in Appendix D of this report.

4.0 SOIL EROSION AND SEDIMENT CONTROL

Soil erosion and sediment control measures have been designed and located within the project site to minimize the amount of sediment carried by stormwater runoff, both during and after construction of the project. The SESC design was completed in accordance with the New Jersey Standards for Soil Erosion and Sediment Control.

5.0 STORMWATER MAINTENANCE PLAN

The stormwater management systems for the proposed development area is intended to collect, convey and detain the stormwater runoff. Regular maintenance procedures are required to verify the consistent and proper operation of the stormwater management facilities and prevent problems and malfunctions. The maintenance program provides the stormwater maintenance procedures for the site, which can be found under separate cover.

6.0 CONCLUSION

The stormwater management systems have been designed so that the post-construction peak runoff rates either meet the required peak rate reductions, or do not exceed at any point in time the pre-construction peak runoff rates, for the 2-, 10-, and 100-year design storm events, depending on the design criteria governing each point of analysis. The proposed small-scale bioretention basins and small-scale infiltration basin have been designed in accordance with the BMP Manual in order to achieve the required TSS removal rate for the project site, while simultaneously providing quantity control for the 2-, 10-, and 100-year design storm events. The

large-scale infiltration basin has been designed to also provide quantity control for the respective storm events. The small-scale infiltration basins have been designed to satisfy the annual groundwater recharge requirements. The proposed stormwater conveyance systems have been designed to safely and effectively convey the runoff generated from the 25-year design storm event. Therefore, the engineering design of the stormwater management systems has been performed in accordance with and meets the regulations specified under the Township of Neptune Code of Ordinances, NJDOT, and the NJDEP stormwater rules.

7.0 REFERENCES

1. Hydrology Studio. Hydrology Studio 2022 v 3.0.0.26.
2. Hydrology Studio. Stormwater Studio 2022 v 3.0.0.29.
3. Urban Hydrology for Small Watersheds, Technical Release No. 55, USDA Soil Conservation Service Publication, June 1986.
4. New Jersey Stormwater Best Management Practices Manual, New Jersey Department of Environmental Protection, Division of Watershed Management, April 2004, last revised April 2021.
5. Township of Neptune Ordinance No. 21-07 – Township Stormwater Management Ordinance, Section 528 of the Land Development Ordinance
6. The Standards for Soil Erosion and Sediment Control in New Jersey, New Jersey Department of Agriculture, revised July 2017.
7. New Jersey Department of Transportation 2015 Roadway Design Manual, last revised July 13, 2022.

\\langan.com\data\PAR\data0\100775001\Project Data\Discipline\Site Civil\Reports\2024-05-03 Stormwater Management Report\Route 66 Neptune Stormwater Management Report.docx

FIGURES

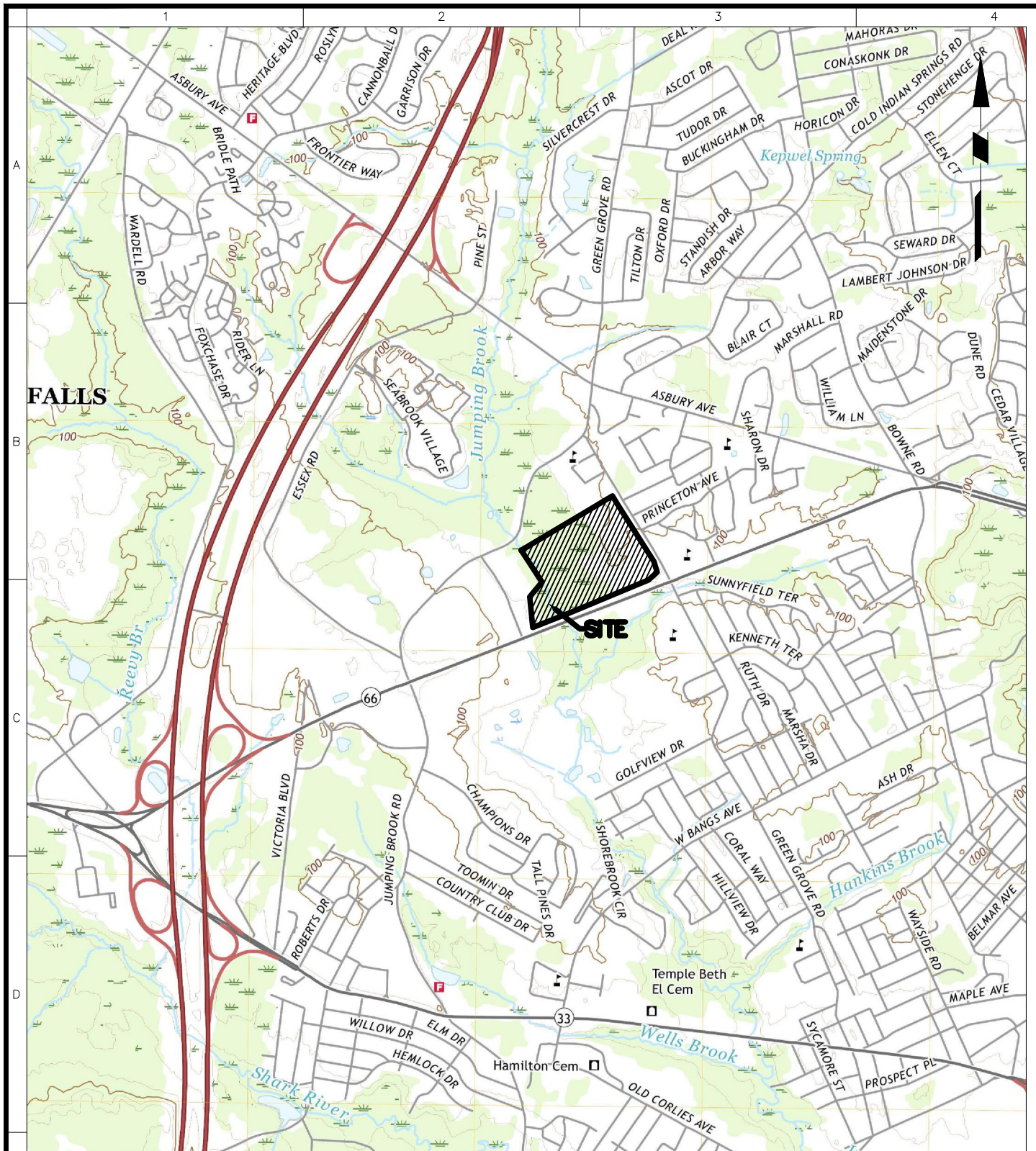

SOURCE: 2019 ASBURY PARK, NJ USGS QUADRANGLE MAP.

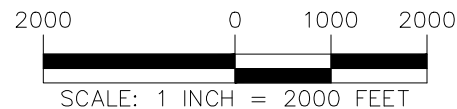

<p>Langan Engineering and Environmental Services, Inc. 300 Kimball Drive Parsippany, NJ 07054 T: 973.560.4900 F: 973.560.4901 www.langan.com NJ CERTIFICATE OF AUTHORIZATION NO. 24GA27996400</p>	Project	Drawing Title	Project No.	Figure
	3501 STATE ROUTE 66 REDEVELOPMENT	SITE LOCATION MAP	100775002	FG01
	BLOCK No. 3903, LOT No 12 & 13		Date	
	NEPTUNE TOWNSHIP		AUGUST 26, 2022	
MONMOUTH COUNTY NEW JERSEY			Drawn By	Sheet 1 of 1
			Checked By	
			SS	
			MV	

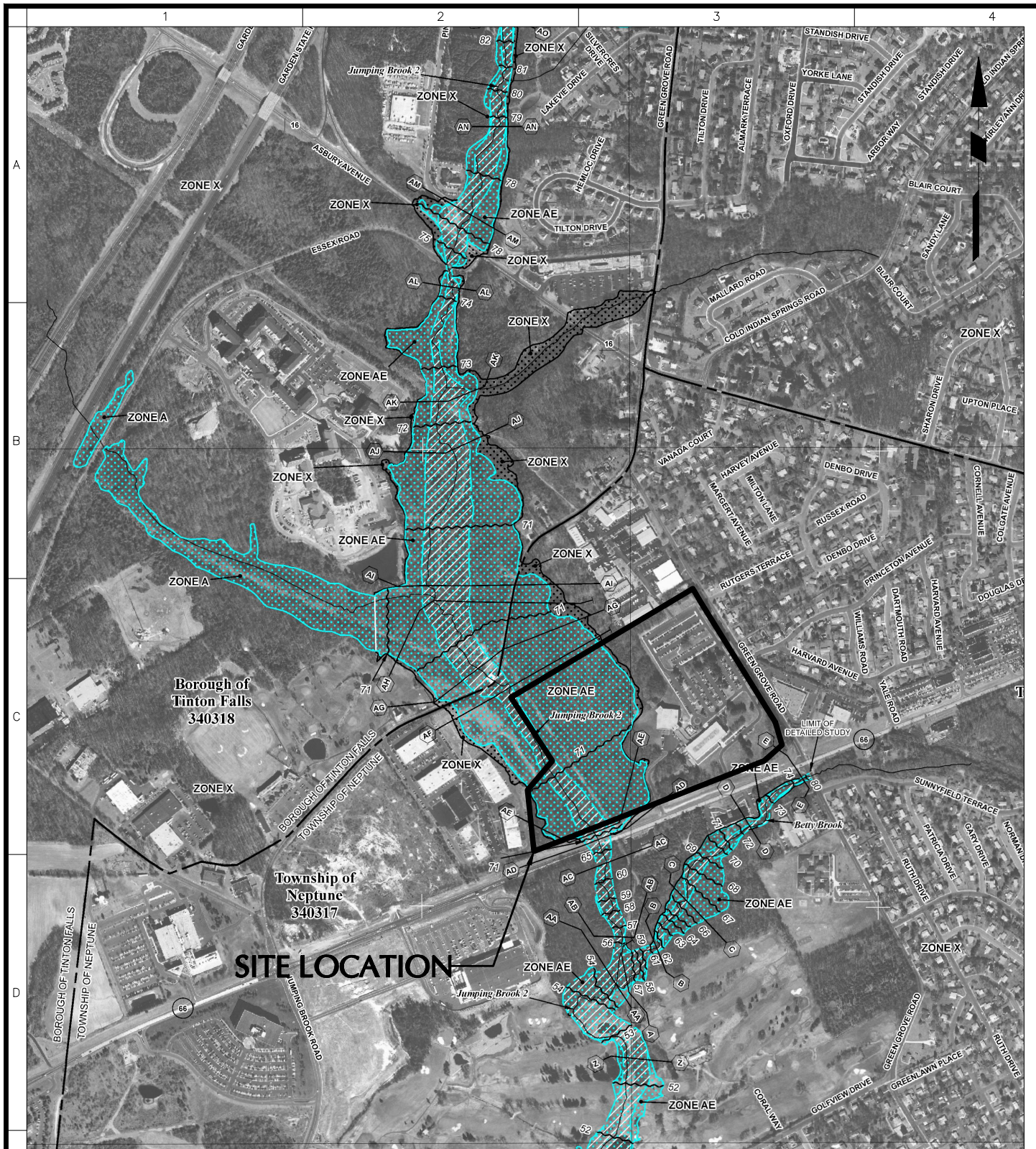

REFERENCE: FEMA FLOOD INSURANCE RATE MAP OF MONMOUTH COUNTY, NEW JERSEY, MAP NUMBER 34025C0327F, EFFECTIVE DATE SEPTEMBER 25, 2009.

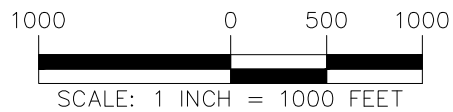

<p>LANGAN Langan Engineering and Environmental Services, Inc. 300 Kimball Drive Parsippany, NJ 07054 T: 973.560.4900 F: 973.560.4901 www.langan.com NJ CERTIFICATE OF AUTHORIZATION NO. 24GA27996400</p>	Project	Drawing Title	Project No.	Figure
	3501 STATE ROUTE 66 REDEVELOPMENT	FLOOD MAP	100775002	FG02
	BLOCK No. 3903, LOT No 12 & 13 NEPTUNE TOWNSHIP		Date AUGUST 26, 2022	
	MONMOUTH COUNTY NEW JERSEY		Drawn By SS Checked By MV	Sheet 1 of 1

- GENERAL NOTES:**
- BACKGROUND BOUNDARY AND TOPOGRAPHIC SURVEY INFORMATION REFERENCED FROM PLAN TITLED "BOUNDARY AND TOPOGRAPHIC SURVEY" PREPARED BY LANGAN ENGINEERING AND ENVIRONMENTAL SERVICES, INC, DATED OCTOBER 27, 2020, AND LAST REVISED AUGUST 4, 2021.
 - HORIZONTAL DATUM REFERENCED TO THE NEW JERSEY STATE PLANE COORDINATE SYSTEM (NAD 83).
 - ELEVATIONS REFERENCED TO THE NORTH AMERICAN VERTICAL DATUM OF 1988 (NAVD 88).
 - THE FRESHWATER WETLANDS/WATERS BOUNDARY LINE DEPICTED ON THE PLANS HAVE BEEN VERIFIED BY THE NEW JERSEY DEPARTMENT OF ENVIRONMENTAL PROTECTION PER THE LETTER OF INTERPRETATION DATED MAY 24, 2021, FILE NO. 1334-029-00021. THE DEPARTMENT HAS DETERMINED THAT ALL FRESHWATER WETLANDS ON-SITE ARE OF INTERMEDIATE RESOURCE VALUE AND HAVE A 50-FOOT FRESHWATER WETLAND TRANSITION AREA BUFFER.
 - THE STATE OF NEW JERSEY HAS DETERMINED THAT ALL OR A PORTION OF THIS LOT LIES IN A FLOOD HAZARD AREA AND/OR RIPARIAN ZONE. CERTAIN ACTIVITIES IN FLOOD HAZARD AREAS AND RIPARIAN ZONES ARE REGULATED BY THE NEW JERSEY DEPARTMENT OF ENVIRONMENTAL PROTECTION AND SOME ACTIVITIES MAY BE PROHIBITED ON THIS SITE OR MAY FIRST REQUIRE A FLOOD HAZARD AREA PERMIT. CONTACT THE WATERSHED AND LAND MANAGEMENT PROGRAM AT (609) 777-0454 FOR MORE INFORMATION PRIOR TO ANY CONSTRUCTION ON-SITE.
 - THE FLOOD HAZARD ELEVATION FOR THE PROJECT SITE WAS DETERMINED USING METHOD 3, THE FEMA FLUVIAL METHOD, AS SET FORTH IN N.J.A.C. 7:13 FLOOD HAZARD AREA CONTROL ACT RULES. THE NEW JERSEY FLOOD HAZARD AREA DESIGN FLOOD (N/JHADF) FOR THE PROJECT SITE HAS BEEN DETERMINED TO BE ELEVATION 72.4 NAVD 88.

SOIL TYPE LEGEND:

AtsAO - HYDROLOGIC SOIL GROUP A/D - ATSON SAND, 0 TO 2 PERCENT SLOPES, NORTHERN TIDEWATER AREA
 DouB - HYDROLOGIC SOIL GROUP A - DOWNER-URBAN LAND COMPLEX, 0 TO 5 PERCENT SLOPES
 EvuB - HYDROLOGIC SOIL GROUP A - EVESBORO-URBAN LAND COMPLEX, 0 TO 5 PERCENT SLOPES
 HumAt - HYDROLOGIC SOIL GROUP A/D - HUMAQUEPTS, 0 TO 3 PERCENT SLOPES, FREQUENTLY FLOODED
 KkhB - HYDROLOGIC SOIL GROUP A/D - KLEU LOAMY SAND-URBAN LAND COMPLEX, 0 TO 5 PERCENT SLOPES
 LasB - HYDROLOGIC SOIL GROUP A - LAKEWOOD SAND, 0 TO 5 PERCENT SLOPES
 MakAt - HYDROLOGIC SOIL GROUP A/D - MANAHAWKIN MUCK, 0 TO 2 PERCENT SLOPES, FREQUENTLY FLOODED

NOTE: EXISTING ON-SITE SOILS CLASSIFIED AS HYDROLOGIC SOIL GROUP A/D ARE ASSUMED TO BE THE HYDROLOGIC SOIL GROUP A FOR THE PURPOSE OF STORMWATER QUANTITY CONTROL AND GROUNDWATER RECHARGE CALCULATIONS.

SOURCE: SOILS BOUNDARIES REFERENCED FROM THE USDA NATURAL RESOURCES CONSERVATION SERVICE (NRCS) CUSTOM SOIL RESOURCE REPORT FOR MONMOUTH COUNTY.

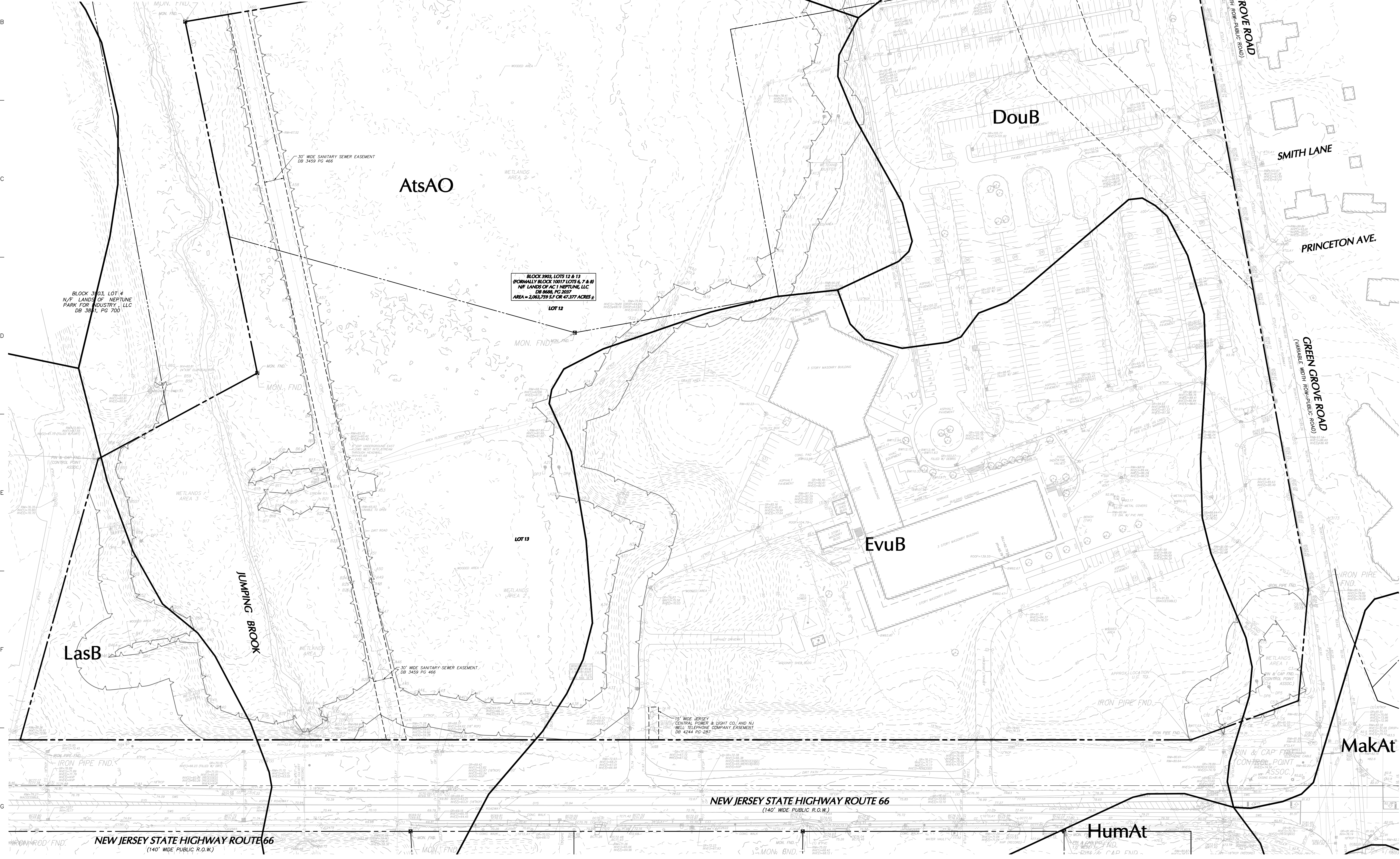

Date	Description	No.
REVISIONS		
SIGNATURE: JOHN COTE DATE SIGNED: _____		
PROFESSIONAL ENGINEER NJ Lic. No. 246E03705800		
LANGAN		
Langan Engineering and Environmental Services, Inc.		
300 Kimball Drive Parsippany, NJ 07054		
T: 973.560.4900 F: 973.560.4901 www.langan.com		
NJ Certificate of Authorization No. 246E03705800		
Project: 3501 STATE ROUTE 66 REDEVELOPMENT		
BLOCK No. 3903, LOT No. 12 & 13 NEPTUNE TOWNSHIP		
MONMOUTH COUNTY NEW JERSEY		
Drawing Title: SOILS MAP		
Project No. 100775002	Figure	FG03
Date: AUGUST 26, 2021		
Drawn By: SS		
Checked By: MVV	Sheet 1 of 1	



- GENERAL NOTES:**
- BACKGROUND BOUNDARY AND TOPOGRAPHIC SURVEY INFORMATION REFERENCED FROM PLAN TITLED "BOUNDARY AND TOPOGRAPHIC SURVEY," PREPARED BY LANGAN ENGINEERING AND ENVIRONMENTAL SERVICES, INC. DATED OCTOBER 27, 2020, AND LAST REVISED AUGUST 4, 2021.
 - HORIZONTAL DATUM REFERENCED TO THE NEW JERSEY STATE PLANE COORDINATE SYSTEM (NAD 83).
 - ELEVATIONS REFERENCED TO THE NORTH AMERICAN VERTICAL DATUM OF 1988 (NAVD 88).
 - THE FRESHWATER WETLANDS/WATERS BOUNDARY LINE DEPICTED ON THE PLANS HAVE BEEN VERIFIED BY THE NEW JERSEY DEPARTMENT OF ENVIRONMENTAL PROTECTION PER THE LETTER OF INTERPRETATION DATED MAY 24, 2021, FILE NO. 1334-09-00023. THE DEPARTMENT HAS DETERMINED THAT ALL FRESHWATER WETLANDS ON-SITE ARE OF INTERMEDIATE RESOURCE VALUE AND HAVE A 50-FOOT FRESHWATER WETLAND TRANSITION AREA BUFFER.
 - THE STATE OF NEW JERSEY HAS DETERMINED THAT ALL OR A PORTION OF THIS LOT LIES IN A FLOOD HAZARD AREA AND/OR RIPARIAN ZONE. CERTAIN ACTIVITIES IN FLOOD HAZARD AREAS AND RIPARIAN ZONES ARE PROHIBITED ON THIS SITE OR MAY FIRST REQUIRE A FLOOD HAZARD AREA PERMIT. CONTACT THE WATERSHED AND LAND MANAGEMENT PROGRAM AT (609) 777-0454 FOR MORE INFORMATION PRIOR TO ANY CONSTRUCTION ON-SITE.
 - THE FLOOD HAZARD ELEVATION FOR THE PROJECT SITE WAS DETERMINED USING METHOD 3, THE FEMA FLUVIAL METHOD, AS SET FORTH IN N.J.A.C. 7:13 FLOOD HAZARD AREA CONTROL ACT RULES. THE NEW JERSEY FLOOD HAZARD AREA DESIGN FLOOD (NFHAD) FOR THE PROJECT SITE HAS BEEN DETERMINED TO BE ELEVATION 72.4 NAVD 88.

PROPERTY LINE/ROW	LEGEND	
	EXISTING	PROPOSED
CONTOUR		
SPOT ELEVATION		
WATERSHED BOUNDARY		
TIME OF CONCENTRATION PATH		

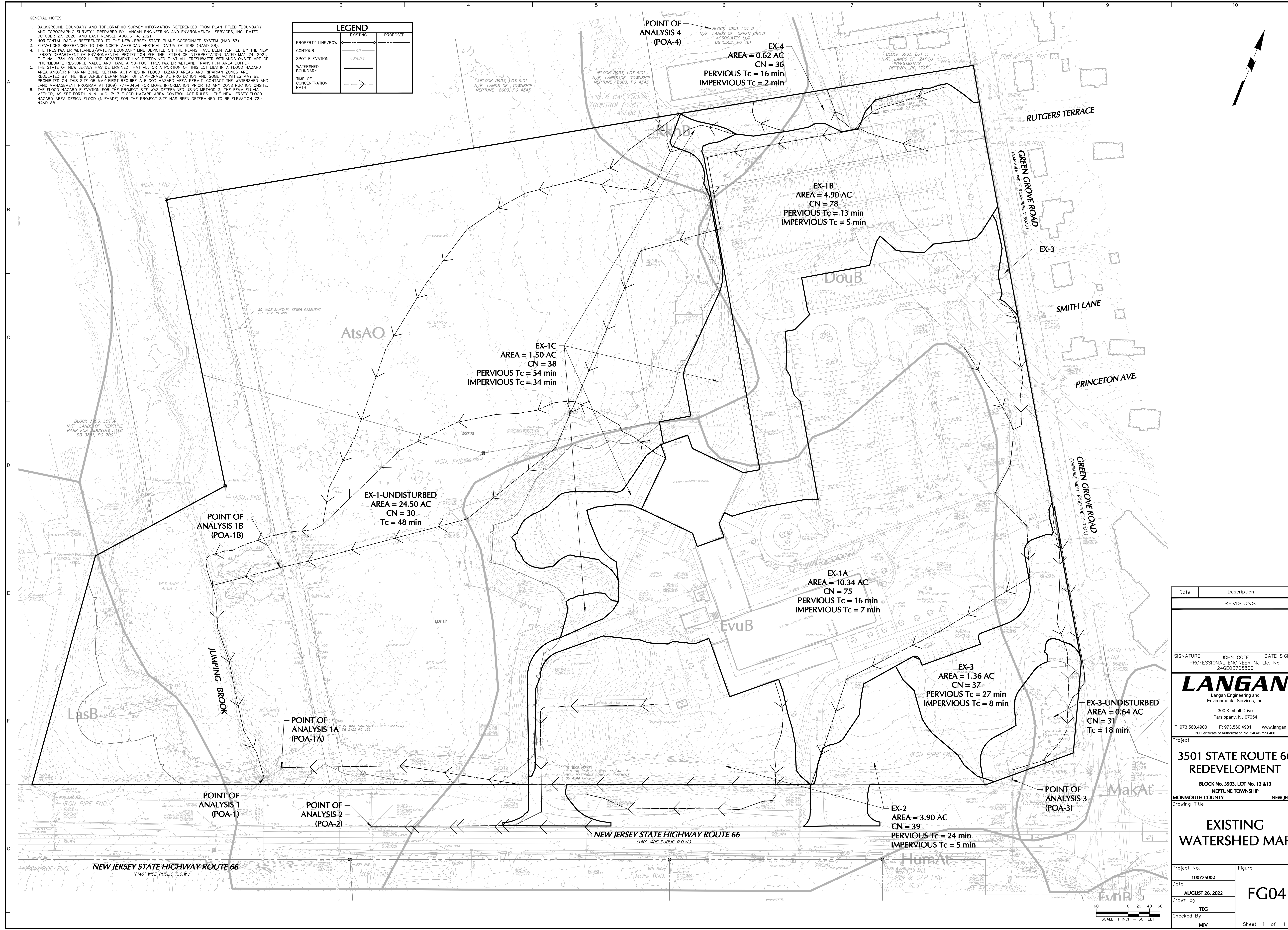

Date	Description	No.
REVISIONS		

SIGNATURE: JOHN COTE DATE SIGNED: _____
 PROFESSIONAL ENGINEER NJ Lic. No. 246E03705800

LANGAN
 Langan Engineering and Environmental Services, Inc.
 300 Kimball Drive
 Parsippany, NJ 07054
 T: 973.560.4900 F: 973.560.4901 www.langan.com
 NJ Certificate of Authorization No. 24G042789640

Project: **3501 STATE ROUTE 66 REDEVELOPMENT**
 BLOCK No. 3903, LOT No. 12 & 13
 NEPTUNE TOWNSHIP
 MONMOUTH COUNTY NEW JERSEY

EXISTING WATERSHED MAP

Project No.	Figure
100775002	FG04
Date	
AUGUST 26, 2022	
Drawn By	
TEG	
Checked By	
MJV	
Sheet	1 of 1

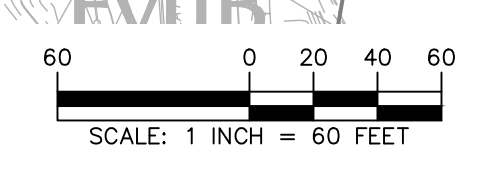

- GENERAL NOTES:**
- BACKGROUND BOUNDARY AND TOPOGRAPHIC SURVEY INFORMATION REFERENCED FROM PLAN TITLED "BOUNDARY AND TOPOGRAPHIC SURVEY," PREPARED BY LANGAN ENGINEERING AND ENVIRONMENTAL SERVICES, INC, DATED OCTOBER 27, 2020, AND LAST REVISED AUGUST 4, 2021.
 - HORIZONTAL DATUM REFERENCED TO THE NEW JERSEY STATE PLANE COORDINATE SYSTEM (NAD 83).
 - ELEVATIONS REFERENCED TO THE NORTH AMERICAN VERTICAL DATUM OF 1988 (NAVD 88).
 - THE FRESHWATER WETLANDS/WATERS BOUNDARY LINE DEPICTED ON THE PLANS HAVE BEEN VERIFIED BY THE NEW JERSEY DEPARTMENT OF ENVIRONMENTAL PROTECTION PER THE LETTER OF INTERPRETATION DATED MAY 24, 2021, FILE NO. 1334-09-0002.1. THE DEPARTMENT HAS DETERMINED THAT ALL FRESHWATER WETLANDS ON-SITE ARE OF INTERMEDIATE RESOURCE VALUE AND HAVE A 50-FOOT FRESHWATER WETLAND TRANSITION AREA BUFFER.
 - THE STATE OF NEW JERSEY HAS DETERMINED THAT ALL OR A PORTION OF THIS LOT LIES IN A FLOOD HAZARD AREA AND/OR RIPARIAN ZONE. CERTAIN ACTIVITIES IN FLOOD HAZARD AREAS AND RIPARIAN ZONES ARE REGULATED BY THE NEW JERSEY DEPARTMENT OF ENVIRONMENTAL PROTECTION AND SOME ACTIVITIES MAY BE PROHIBITED ON THIS SITE OR MAY FIRST REQUIRE A FLOOD HAZARD AREA PERMIT. CONTACT THE WATERSHED AND LAND MANAGEMENT PROGRAM AT (609) 777-4564 FOR MORE INFORMATION PRIOR TO ANY CONSTRUCTION ON-SITE.
 - THE FLOOD HAZARD ELEVATION FOR THE PROJECT SITE WAS DETERMINED USING METHOD 3, THE FEMA FLUVIAL METHOD, AS SET FORTH IN N.J.A.C. 7:13 FLOOD HAZARD AREA CONTROL ACT RULES. THE NEW JERSEY FLOOD HAZARD AREA DESIGN FLOOD (NFHAD) FOR THE PROJECT SITE HAS BEEN DETERMINED TO BE ELEVATION 72.4 NAVD 88.

	LEGEND	
	EXISTING	PROPOSED
PROPERTY LINE/ROW		
CONTOUR		
SPOT ELEVATION		
WATERSHED BOUNDARY		
TIME OF CONCENTRATION PATH		

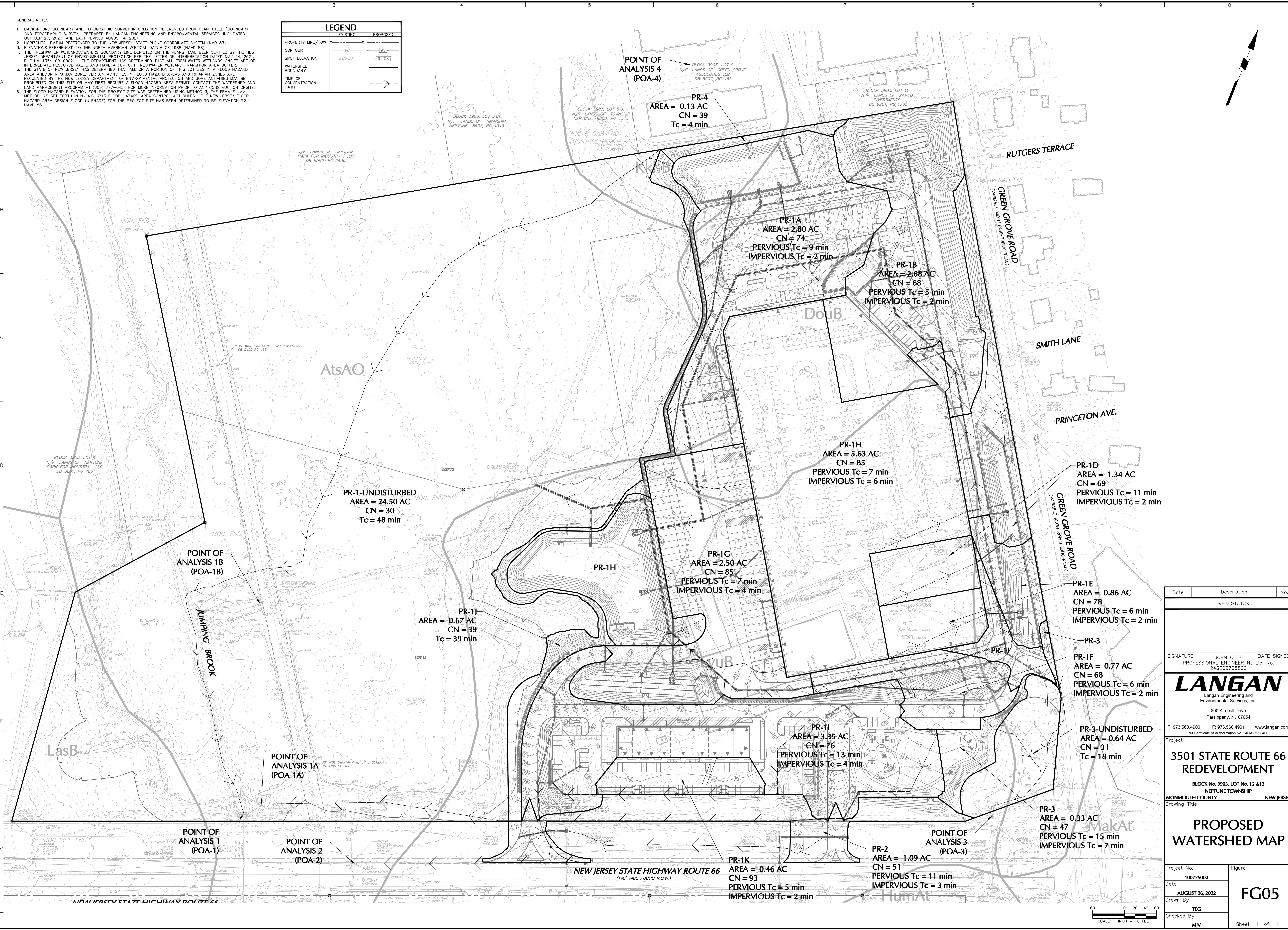

Date	Description	No.
REVISIONS		
SIGNATURE: JOHN COTE DATE SIGNED: []		
PROFESSIONAL ENGINEER NJ Lic. No. 246E03705800		
LANGAN		
Langan Engineering and Environmental Services, Inc. 300 Kimball Drive Parsippany, NJ 07054		
T: 973.560.4900 F: 973.560.4901 www.langan.com NJ Certificate of Authorization No. 246A27896409		
Project: 3501 STATE ROUTE 66 REDEVELOPMENT		
BLOCK No. 3903, LOT No. 12 & 13 NEPTUNE TOWNSHIP MONMOUTH COUNTY NEW JERSEY		
PROPOSED WATERSHED MAP		
Project No.	Figure	
100775002	FG05	
Date	AUGUST 26, 2022	
Drawn By	TEG	
Checked By	MVV	
Sheet 1 of 1		

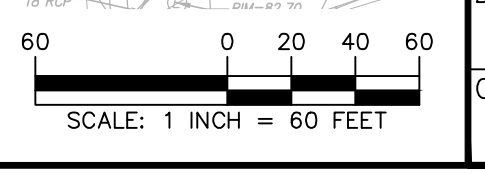

- GENERAL NOTES:**
- BACKGROUND BOUNDARY AND TOPOGRAPHIC SURVEY INFORMATION REFERENCED FROM PLAN TITLED "BOUNDARY AND TOPOGRAPHIC SURVEY" PREPARED BY LANGAN ENGINEERING AND ENVIRONMENTAL SERVICES, INC. DATED OCTOBER 27, 2020, AND LAST REVISED AUGUST 4, 2021.
 - HORIZONTAL DATUM REFERENCED TO THE NEW JERSEY STATE PLANE COORDINATE SYSTEM (NAD 83).
 - ELEVATIONS REFERENCED TO THE NORTH AMERICAN VERTICAL DATUM OF 1988 (NAVD 88).
 - THE FRESHWATER WETLANDS/WATERS BOUNDARY LINE DEPICTED ON THE PLANS HAVE BEEN VERIFIED BY THE NEW JERSEY DEPARTMENT OF ENVIRONMENTAL PROTECTION PER THE LETTER OF INTERPRETATION DATED MAY 24, 2021, FILE NO. 1324-20-00021. THE DEPARTMENT HAS DETERMINED THAT ALL FRESHWATER WETLANDS ON-SITE ARE OF INTERMEDIATE RESOURCE VALUE AND HAVE A 50-FOOT FRESHWATER WETLAND TRANSITION AREA BUFFER.
 - THE STATE OF NEW JERSEY HAS DETERMINED THAT ALL OR A PORTION OF THIS LOT LIES IN A FLOOD HAZARD AREA AND/OR RIPARIAN ZONE. CERTAIN ACTIVITIES IN FLOOD HAZARD AREAS AND RIPARIAN ZONES ARE REGULATED BY THE NEW JERSEY DEPARTMENT OF ENVIRONMENTAL PROTECTION AND SOME ACTIVITIES MAY BE PROHIBITED ON THIS SITE OR MAY FIRST REQUIRE A FLOOD HAZARD AREA PERMIT. CONTACT THE WATERSHED AND LAND MANAGEMENT PROGRAM AT (609) 777-0454 FOR MORE INFORMATION PRIOR TO ANY CONSTRUCTION ON-SITE.
 - THE FLOOD HAZARD ELEVATION FOR THE PROJECT SITE WAS DETERMINED USING METHOD 3, THE FEMA FLUVIAL METHOD, AS SET FORTH IN N.J.A.C. 7:13 FLOOD HAZARD AREA CONTROL ACT RULES. THE NEW JERSEY FLOOD HAZARD AREA DESIGN FLOOD (NFHAD) FOR THE PROJECT SITE HAS BEEN DETERMINED TO BE ELEVATION 72.4 NAVD 88.

LEGEND		
PROPERTY LINE/ROW	EXISTING	PROPOSED
CONTOUR	00	95
SPOT ELEVATION	66.53	92.08
STORM MANHOLE	○	●
CATCH BASIN	□	■
STORM SEWER	—	—
DRAINAGE AREA BOUNDARY	—	—

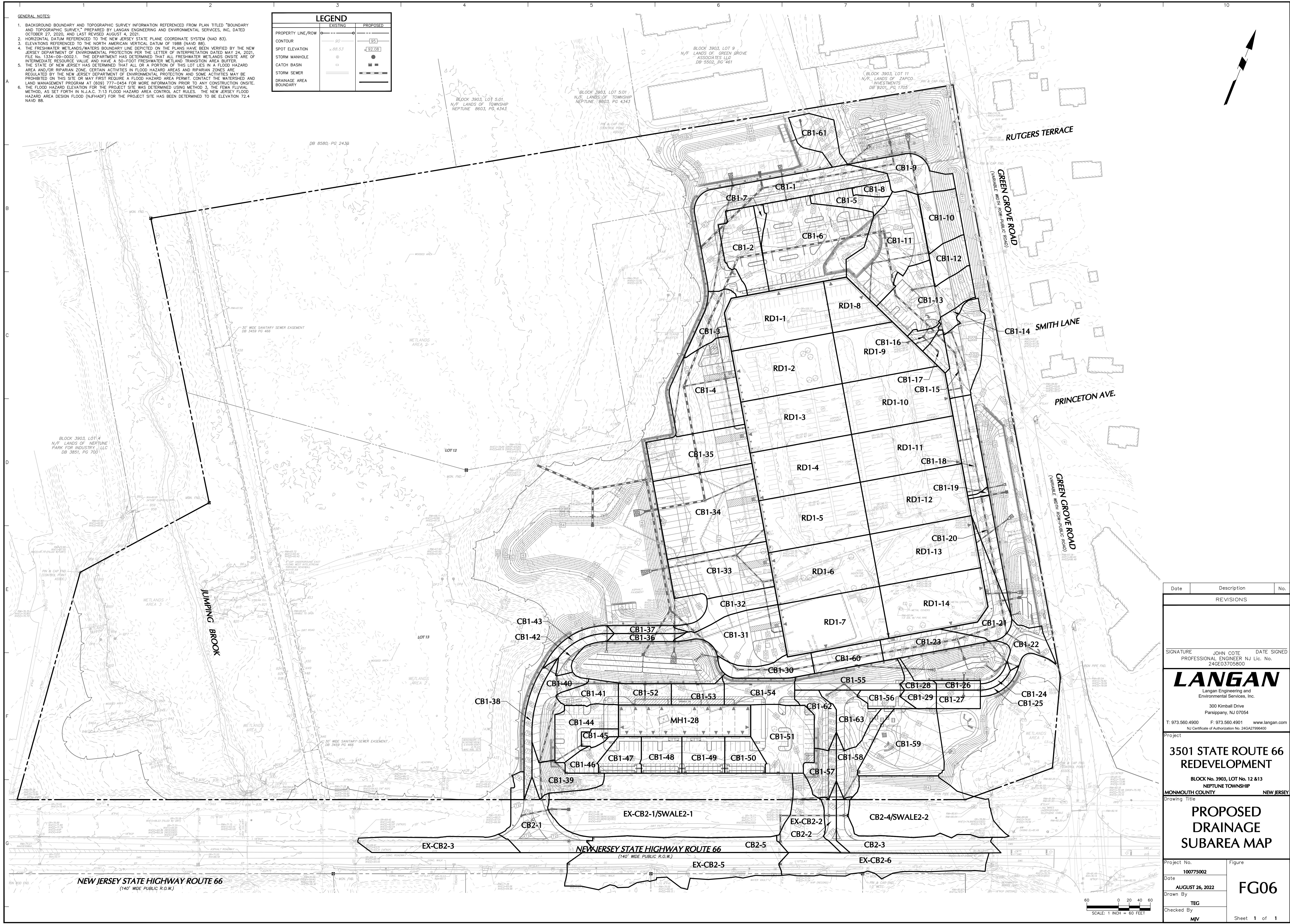

Date	Description	No.
REVISIONS		

SIGNATURE: JOHN COTE DATE SIGNED: PROFESSIONAL ENGINEER NJ Lic. No. 246E03705800

LANGAN
 Langan Engineering and Environmental Services, Inc.
 300 Kimball Drive
 Parsippany, NJ 07054
 T: 973.560.4900 F: 973.560.4901 www.langan.com
 NJ Certificate of Authorization No. 246A27896403

Project: **3501 STATE ROUTE 66 REDEVELOPMENT**
 BLOCK No. 3903, LOT No. 12 & 13
 NEPTUNE TOWNSHIP
 MONMOUTH COUNTY NEW JERSEY

Drawing Title: **PROPOSED DRAINAGE SUBAREA MAP**

Project No. 100775002	Figure FG06
Date: AUGUST 26, 2022	
Drawn By: TEG	
Checked By: MVV	
Sheet 1 of 1	

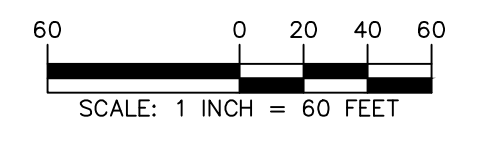

- GENERAL NOTES:**
- BACKGROUND BOUNDARY AND TOPOGRAPHIC SURVEY INFORMATION REFERENCED FROM PLAN TITLED "BOUNDARY AND TOPOGRAPHIC SURVEY" PREPARED BY LANGAN ENGINEERING AND ENVIRONMENTAL SERVICES, INC., DATED OCTOBER 27, 2020, AND LAST REVISED AUGUST 4, 2021.
 - HORIZONTAL DATUM REFERENCED TO THE NEW JERSEY STATE PLANE COORDINATE SYSTEM (NAD 83).
 - ELEVATIONS REFERENCED TO THE NORTH AMERICAN VERTICAL DATUM OF 1988 (NAVD 88).
 - THE FRESHWATER WETLANDS/WATERS BOUNDARY LINE DEPICTED ON THE PLANS HAVE BEEN VERIFIED BY THE NEW JERSEY DEPARTMENT OF ENVIRONMENTAL PROTECTION PER THE LETTER OF INTERPRETATION DATED MAY 24, 2021, FILE NO. 1334-09-00021. THE DEPARTMENT HAS DETERMINED THAT ALL FRESHWATER WETLANDS ON-SITE ARE OF INTERMEDIATE RESOURCE VALUE AND HAVE A 50-FOOT FRESHWATER WETLAND TRANSITION AREA BUFFER.
 - THE STATE OF NEW JERSEY HAS DETERMINED THAT ALL OR A PORTION OF THIS LOT LIES IN A FLOOD HAZARD AREA AND/OR RIPARIAN ZONE. CERTAIN ACTIVITIES IN FLOOD HAZARD AREAS AND RIPARIAN ZONES ARE REGULATED BY THE NEW JERSEY DEPARTMENT OF ENVIRONMENTAL PROTECTION AND SOME ACTIVITIES MAY BE PROHIBITED ON THIS SITE OR MAY FIRST REQUIRE A FLOOD HAZARD AREA PERMIT. CONTACT THE WATERSHED AND LAND MANAGEMENT PROGRAM AT (609) 777-0454 FOR MORE INFORMATION PRIOR TO ANY CONSTRUCTION ON-SITE.
 - THE FLOOD HAZARD ELEVATION FOR THE PROJECT SITE WAS DETERMINED USING METHOD 3, THE FEMA FLUMINAL METHOD, AS SET FORTH IN N.J.A.C. 7:13 FLOOD HAZARD AREA CONTROL ACT RULES. THE NEW JERSEY FLOOD HAZARD AREA DESIGN FLOOD (NFHAD) FOR THE PROJECT SITE HAS BEEN DETERMINED TO BE ELEVATION 72.4 NAVD 88.

PROPERTY LINE/ROW	EXISTING	PROPOSED
	○	○
CONTOUR	— 50	— 55
SPOT ELEVATION	× 88.53	× 92.08
STORM MANHOLE	●	●
CATCH BASIN	□	□
STORM SEWER	—	—
DRAINAGE AREA BOUNDARY	—	—

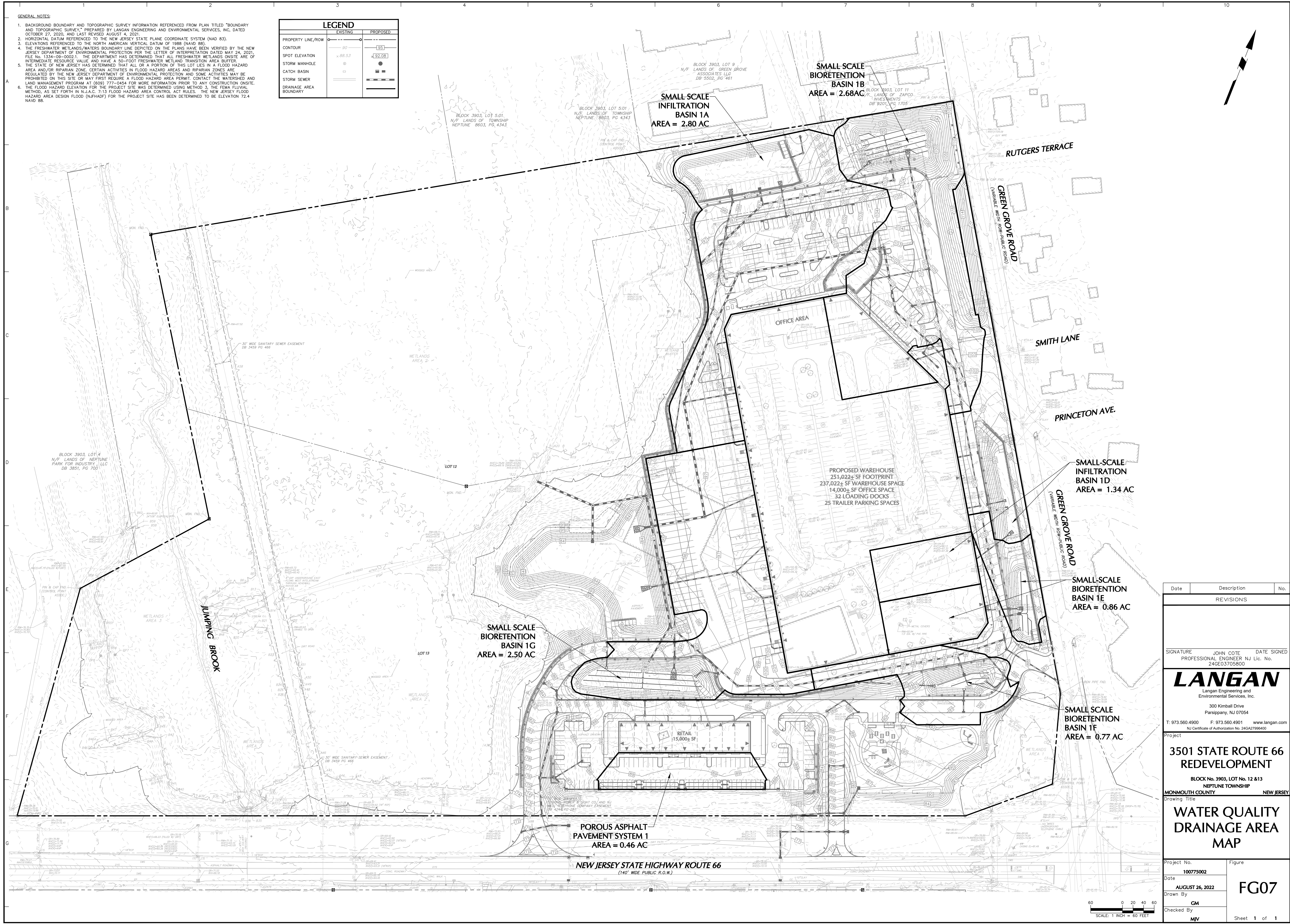

Date	Description	No.
REVISIONS		
SIGNATURE: JOHN COTE DATE SIGNED: _____ PROFESSIONAL ENGINEER NJ Lic. No. 246E03705800		
LANGAN Langan Engineering and Environmental Services, Inc. 300 Kimball Drive Parsippany, NJ 07054 T: 973.560.4900 F: 973.560.4901 www.langan.com NJ Certificate of Authorization No. 246A27896400		
Project: 3501 STATE ROUTE 66 REDEVELOPMENT BLOCK No. 3903, LOT No. 12 & 13 NEPTUNE TOWNSHIP MONMOUTH COUNTY NEW JERSEY		
DRAINAGE AREA MAP		
Project No. 100775002	Figure FG07	
Date: AUGUST 26, 2022	Drawn By: GM	Checked By: MVV
SCALE: 1" = 60 FEET		Sheet 1 of 1

- GENERAL NOTES:**
1. BACKGROUND BOUNDARY AND TOPOGRAPHIC SURVEY INFORMATION REFERENCED FROM PLAN TITLED "BOUNDARY AND TOPOGRAPHIC SURVEY" PREPARED BY LANGAN ENGINEERING AND ENVIRONMENTAL SERVICES, INC. DATED OCTOBER 27, 2020, AND LAST REVISED AUGUST 4, 2021.
 2. HORIZONTAL DATUM REFERENCED TO THE NEW JERSEY STATE PLANE COORDINATE SYSTEM (NAD 83).
 3. ELEVATIONS REFERENCED TO THE NORTH AMERICAN VERTICAL DATUM OF 1988 (NAVD 88).
 4. THE FRESHWATER WETLANDS/WATERS BOUNDARY LINE DEPICTED ON THE PLANS HAVE BEEN VERIFIED BY THE NEW JERSEY DEPARTMENT OF ENVIRONMENTAL PROTECTION PER THE LETTER OF INTERPRETATION DATED MAY 24, 2021, FILE NO. 1334-09-00021. THE DEPARTMENT HAS DETERMINED THAT ALL FRESHWATER WETLANDS ON-SITE ARE OF INTERMEDIATE RESOURCE VALUE AND HAVE A 50-FOOT FRESHWATER WETLAND TRANSITION AREA BUFFER.
 5. THE STATE OF NEW JERSEY HAS DETERMINED THAT ALL OR A PORTION OF THIS LOT LIES IN A FLOOD HAZARD AREA AND/OR RIPARIAN ZONE. CERTAIN ACTIVITIES IN FLOOD HAZARD AREAS AND RIPARIAN ZONES ARE REGULATED BY THE NEW JERSEY DEPARTMENT OF ENVIRONMENTAL PROTECTION AND SOME ACTIVITIES MAY BE PROHIBITED ON THIS SITE OR MAY FIRST REQUIRE A FLOOD HAZARD AREA PERMIT. CONTACT THE WATERSHED AND LAND MANAGEMENT PROGRAM AT (609) 777-0454 FOR MORE INFORMATION PRIOR TO ANY CONSTRUCTION ON-SITE.
 6. THE FLOOD HAZARD ELEVATION FOR THE PROJECT SITE WAS DETERMINED USING METHOD 3, THE FEMA FLUVIAL METHOD, AS SET FORTH IN N.J.A.C. 7.13 FLOOD HAZARD AREA CONTROL ACT RULES. THE NEW JERSEY FLOOD HAZARD AREA DESIGN FLOOD (NFHAD) FOR THE PROJECT SITE HAS BEEN DETERMINED TO BE ELEVATION 72.4 NAVD 88.

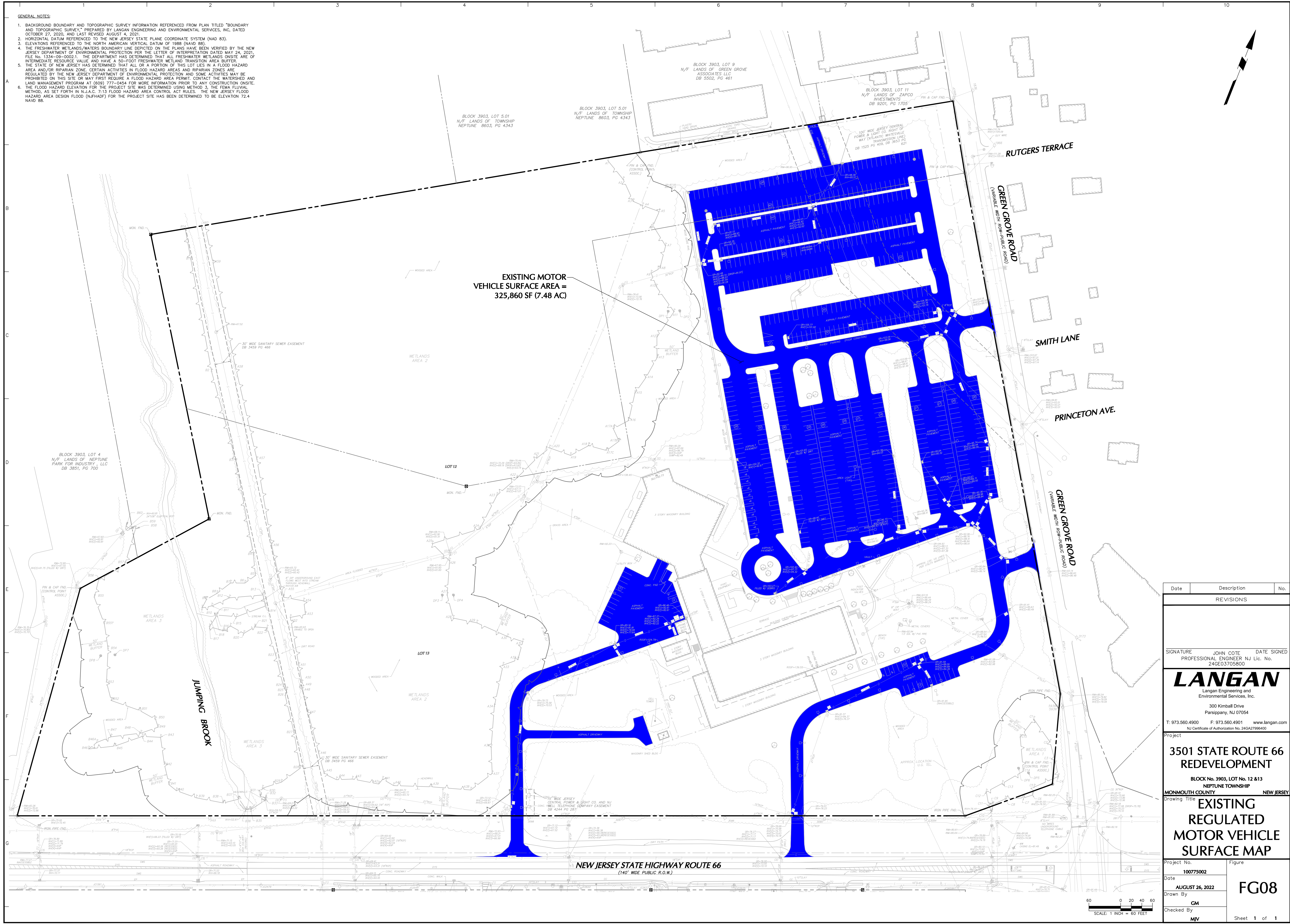

EXISTING MOTOR
VEHICLE SURFACE AREA =
325,860 SF (7.48 AC)

Date	Description	No.
REVISIONS		
SIGNATURE: JOHN COTE DATE SIGNED: _____ PROFESSIONAL ENGINEER NJ Lic. No. 246E03705800		
LANGAN Langan Engineering and Environmental Services, Inc. 300 Kimball Drive Parsippany, NJ 07054 T: 973.560.4900 F: 973.560.4901 www.langan.com NJ Certificate of Authorization No. 246A27896403		
Project: 3501 STATE ROUTE 66 REDEVELOPMENT BLOCK No. 3903, LOT No. 12 & 13 NEPTUNE TOWNSHIP MONMOUTH COUNTY NEW JERSEY		
Drawing Title: EXISTING REGULATED MOTOR VEHICLE SURFACE MAP		
Project No. 100775002	Figure	FG08
Date: AUGUST 26, 2022	Drawn By: GM	Checked By: MV
SCALE: 1 INCH = 60 FEET		Sheet 1 of 1

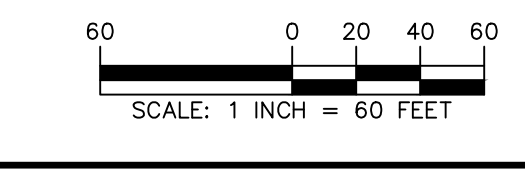

- GENERAL NOTES:**
1. BACKGROUND BOUNDARY AND TOPOGRAPHIC SURVEY INFORMATION REFERENCED FROM PLAN TITLED "BOUNDARY AND TOPOGRAPHIC SURVEY," PREPARED BY LANGAN ENGINEERING AND ENVIRONMENTAL SERVICES, INC., DATED OCTOBER 27, 2020, AND LAST REVISED AUGUST 4, 2021.
 2. HORIZONTAL DATUM REFERENCED TO THE NEW JERSEY STATE PLANE COORDINATE SYSTEM (NAD 83).
 3. ELEVATIONS REFERENCED TO THE NORTH AMERICAN VERTICAL DATUM OF 1988 (NAVD 88).
 4. THE FRESHWATER WETLANDS/WATERS BOUNDARY LINE DEPICTED ON THE PLANS HAVE BEEN VERIFIED BY THE NEW JERSEY DEPARTMENT OF ENVIRONMENTAL PROTECTION PER THE LETTER OF INTERPRETATION DATED MAY 24, 2021, FILE NO. 1334-03-00021. THE DEPARTMENT HAS DETERMINED THAT ALL FRESHWATER WETLANDS ON-SITE ARE OF INTERMEDIATE RESOURCE VALUE AND HAVE A 50-FOOT FRESHWATER WETLAND TRANSITION AREA BUFFER.
 5. THE STATE OF NEW JERSEY HAS DETERMINED THAT ALL OR A PORTION OF THIS LOT LIES IN A FLOOD HAZARD AREA AND/OR RIPARIAN ZONE. CERTAIN ACTIVITIES IN FLOOD HAZARD AREAS AND RIPARIAN ZONES ARE REGULATED BY THE NEW JERSEY DEPARTMENT OF ENVIRONMENTAL PROTECTION AND SOME ACTIVITIES MAY BE PROHIBITED ON THIS SITE OR MAY FIRST REQUIRE A FLOOD HAZARD AREA PERMIT. CONTACT THE WATERSHED AND LAND MANAGEMENT PROGRAM AT (609) 777-0454 FOR MORE INFORMATION PRIOR TO ANY CONSTRUCTION ON-SITE.
 6. THE FLOOD HAZARD ELEVATION FOR THE PROJECT SITE WAS DETERMINED USING METHOD 3, THE FEMA FLUMINAL METHOD, AS SET FORTH IN N.J.A.C. 7:13 FLOOD HAZARD AREA CONTROL ACT RULES. THE NEW JERSEY FLOOD HAZARD AREA DESIGN FLOOD (NFHAD) FOR THE PROJECT SITE HAS BEEN DETERMINED TO BE ELEVATION 72.4 NAVD 88.

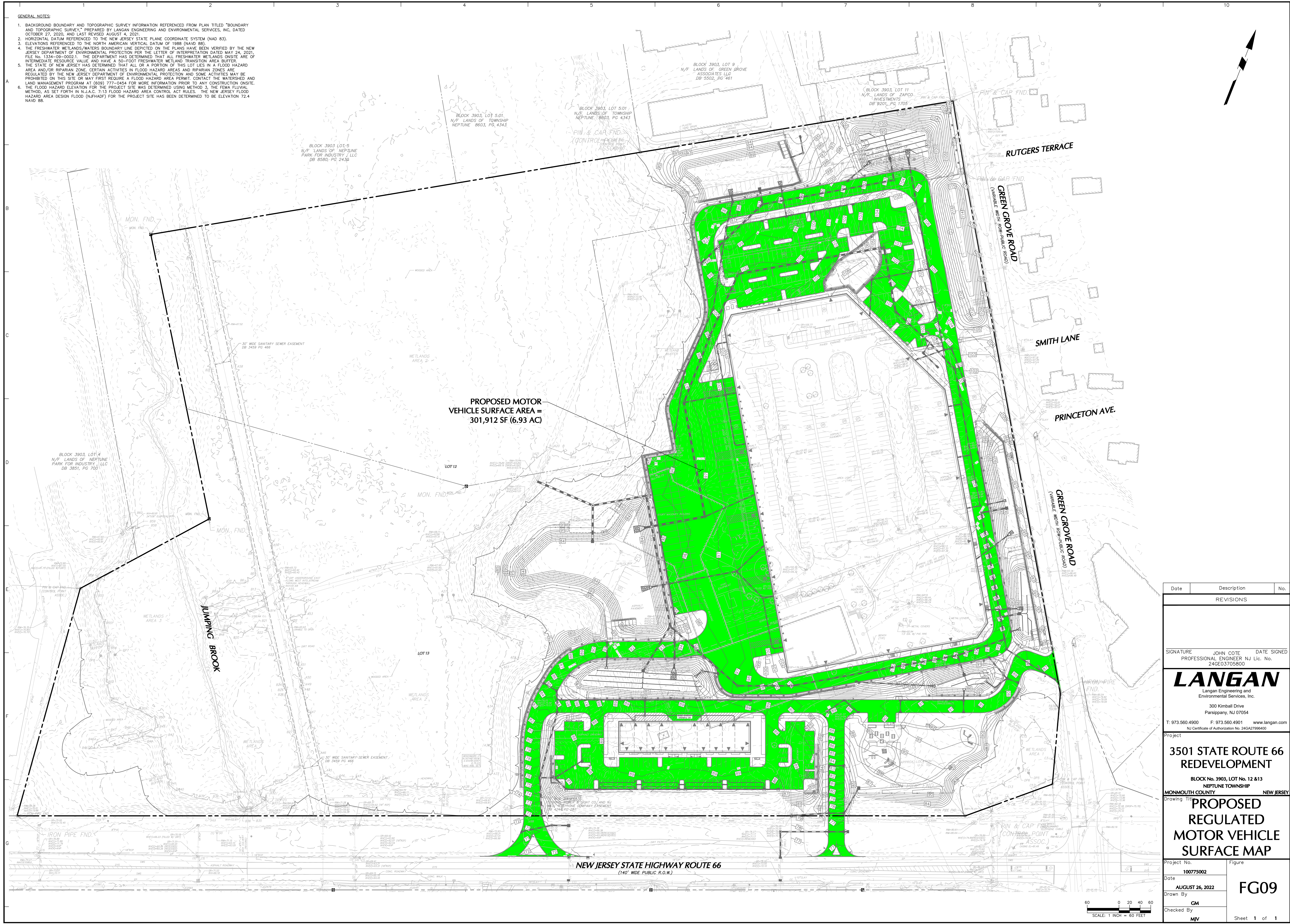

PROPOSED MOTOR VEHICLE SURFACE AREA = 301,912 SF (6.93 AC)

Date	Description	No.
REVISIONS		
SIGNATURE: JOHN COTE DATE SIGNED: []		
PROFESSIONAL ENGINEER NJ Lic. No. 246E03705800		
LANGAN		
Langan Engineering and Environmental Services, Inc.		
300 Kimball Drive Parsippany, NJ 07054		
T: 973.560.4900 F: 973.560.4901 www.langan.com NJ Certificate of Authorization No. 246A27896409		
Project: 3501 STATE ROUTE 66 REDEVELOPMENT		
BLOCK No. 3903, LOT No. 12 & 13 NEPTUNE TOWNSHIP		
MONMOUTH COUNTY NEW JERSEY		
Drawing Title: PROPOSED REGULATED MOTOR VEHICLE SURFACE MAP		
Project No.	Figure	
100775002	FG09	
Date:	AUGUST 26, 2022	
Drawn By:	GM	
Checked By:	MV	
Sheet 1 of 1		

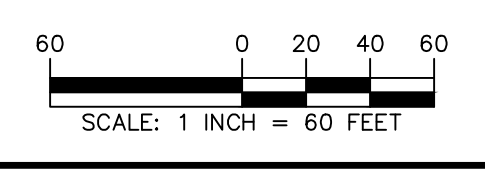

- GENERAL NOTES:**
- BACKGROUND BOUNDARY AND TOPOGRAPHIC SURVEY INFORMATION REFERENCED FROM PLAN TITLED "BOUNDARY AND TOPOGRAPHIC SURVEY," PREPARED BY LANGAN ENGINEERING AND ENVIRONMENTAL SERVICES, INC, DATED OCTOBER 27, 2020, AND LAST REVISED AUGUST 4, 2021.
 - HORIZONTAL DATUM REFERENCED TO THE NEW JERSEY STATE PLANE COORDINATE SYSTEM (NAD 83).
 - ELEVATIONS REFERENCED TO THE NORTH AMERICAN VERTICAL DATUM OF 1988 (NAVD 88).
 - THE FRESHWATER WETLANDS/WATERS BOUNDARY LINE DEPICTED ON THE PLANS HAVE BEEN VERIFIED BY THE NEW JERSEY DEPARTMENT OF ENVIRONMENTAL PROTECTION PER THE LETTER OF INTERPRETATION DATED MAY 24, 2021, FILE NO. 1334-09-0002.1. THE DEPARTMENT HAS DETERMINED THAT ALL FRESHWATER WETLANDS ON-SITE ARE OF INTERMEDIATE RESOURCE VALUE AND HAVE A 50-FOOT FRESHWATER WETLAND TRANSITION AREA BUFFER.
 - THE STATE OF NEW JERSEY HAS DETERMINED THAT ALL OR A PORTION OF THIS LOT LIES IN A FLOOD HAZARD AREA AND/OR RIPARIAN ZONE. CERTAIN ACTIVITIES IN FLOOD HAZARD AREAS AND RIPARIAN ZONES ARE REGULATED BY THE NEW JERSEY DEPARTMENT OF ENVIRONMENTAL PROTECTION AND SOME ACTIVITIES MAY BE PROHIBITED ON THIS SITE OR MAY FIRST REQUIRE A FLOOD HAZARD AREA PERMIT. CONTACT THE WATERSHED AND LAND MANAGEMENT PROGRAM AT (609) 777-0454 FOR MORE INFORMATION PRIOR TO ANY CONSTRUCTION ON-SITE.
 - THE FLOOD HAZARD ELEVATION FOR THE PROJECT SITE WAS DETERMINED USING METHOD 3, THE FEMA FLUVIAL METHOD, AS SET FORTH IN N.J.A.C. 7:13 FLOOD HAZARD AREA CONTROL ACT RULES. THE NEW JERSEY FLOOD HAZARD AREA DESIGN FLOOD (NFHAD) FOR THE PROJECT SITE HAS BEEN DETERMINED TO BE ELEVATION 72.4 NAVD 88.

LEGEND		
	EXISTING	PROPOSED
PROPERTY LINE/ROW		
CONTOUR		
SPOT ELEVATION		
WATERSHED BOUNDARY		
TIME OF CONCENTRATION PATH		

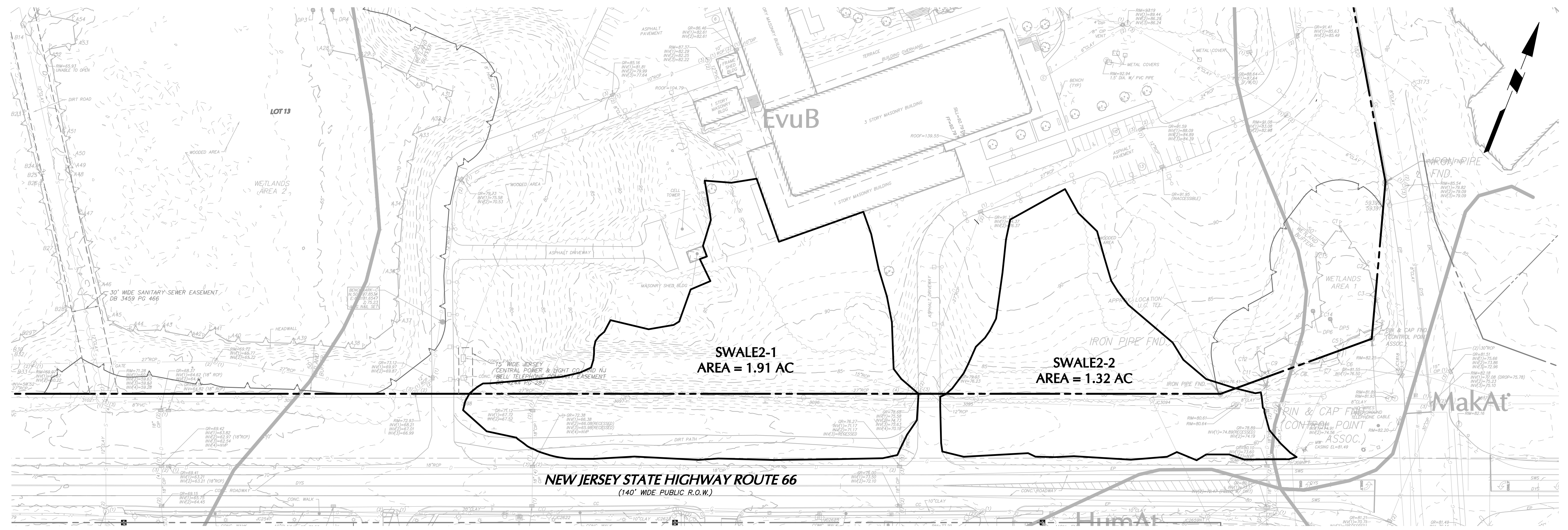

EXISTING SWALE WATERSHED MAP

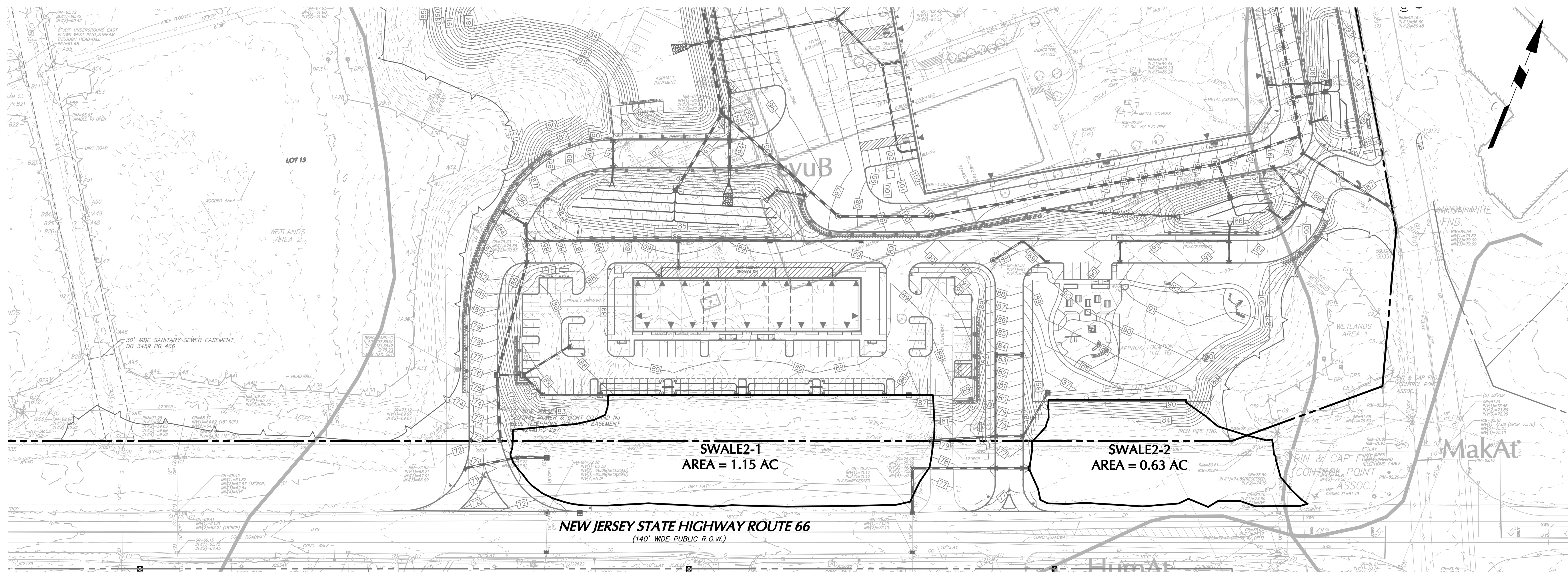

PROPOSED SWALE WATERSHED MAP

Date	Description	No.
REVISIONS		
SIGNATURE: JOHN COTE DATE SIGNED: []		
PROFESSIONAL ENGINEER NJ Lic. No. 246E03705800		
LANGAN		
Langan Engineering and Environmental Services, Inc. 300 Kimball Drive Parsippany, NJ 07054		
T: 973.560.4900 F: 973.560.4901 www.langan.com NJ Certificate of Authorization No. 24G427896400		
Project		
3501 STATE ROUTE 66 REDEVELOPMENT		
BLOCK No. 3903, LOT No. 12 & 13 NEPTUNE TOWNSHIP MONMOUTH COUNTY NEW JERSEY		
Drawing Title		
NJDOT SWALE WATERSHED MAP		
Project No.	Figure	
100775002	FG10	
Date	MAY 5, 2023	
Drawn By	TEG	
Checked By	MIV	
Sheet 1 of 1		

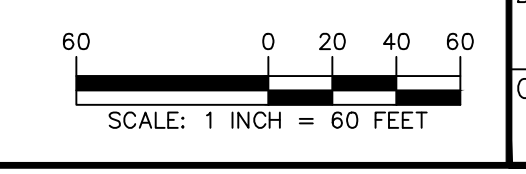

DRAWINGS

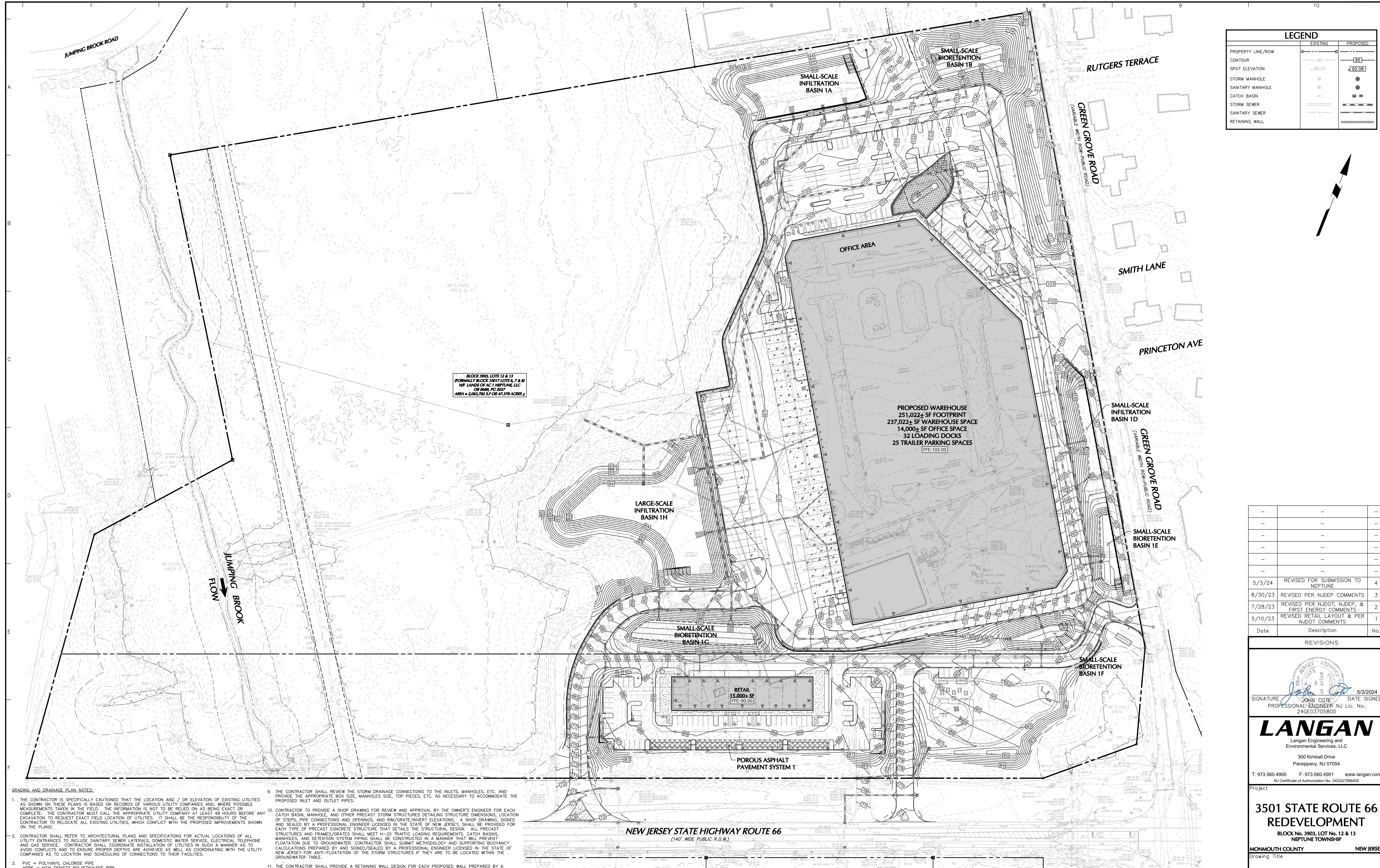

Date	Description	No.
5/3/24	REVISED FOR SUBMISSION TO NEPTUNE	4
8/30/23	REVISED PER NJDEP COMMENTS	3
7/28/23	REVISED PER NJDEP, NJDEP, & FIRST ENERGY COMMENTS	2
5/10/23	REVISED RETAIL LAYOUT & PER NJDEP COMMENTS	1

REVISIONS

SIGNATURE: *John Cote* DATE SIGNED: 5/3/2024
 PROFESSIONAL ENGINEER NJ Lic. No. 246E03705800

LANGAN
Langan Engineering and Environmental Services, LLC
300 Kimball Drive
Parsippany, NJ 07054
T: 973.560.4900 F: 973.560.4901 www.langan.com
NJ Certificate of Authorization No. 246A27896403

Project
3501 STATE ROUTE 66 REDEVELOPMENT
BLOCK No. 3903, LOT No. 12 & 13
NEPTUNE TOWNSHIP
MONMOUTH COUNTY NEW JERSEY

Drawing Title
OVERALL GRADING PLAN

Project No. 100775002 Drawing No. CG100
Date AUGUST 26, 2022
Drawn By TEG
Checked By MVJ
Sheet 19 of 48

LEGEND	
EXISTING	PROPOSED
PROPERTY LINE/ROW	---
CONTOUR	---
SPOT ELEVATION	---
STORM MANHOLE	---
SANITARY MANHOLE	---
CATCH BASIN	---
STORM SEWER	---
SANITARY SEWER	---
RETAINING WALL	---

GENERAL NOTES:

- BACKGROUND BOUNDARY AND TOPOGRAPHIC SURVEY INFORMATION REFERENCED FROM PLAN TITLED "BOUNDARY AND TOPOGRAPHIC SURVEY," PREPARED BY LANGAN ENGINEERING AND ENVIRONMENTAL SERVICES, LLC, DATED OCTOBER 27, 2020, AND LAST REVISED AUGUST 4, 2021.
- HORIZONTAL DATUM REFERENCED TO THE NEW JERSEY STATE PLANE COORDINATE SYSTEM (NAO 83).
- ELEVATIONS REFERENCED TO THE NORTH AMERICAN VERTICAL DATUM OF 1988 (NAVD 88).
- THE FRESHWATER WETLANDS/WATERS BOUNDARY LINE DEPICTED ON THE PLANS HAVE BEEN VERIFIED BY THE NEW JERSEY DEPARTMENT OF ENVIRONMENTAL PROTECTION PER THE LETTER OF INTERPRETATION DATED MAY 24, 2021, FILE NO. 1334-09-00021. THE DEPARTMENT HAS DETERMINED THAT ALL FRESHWATER WETLANDS ON-SITE ARE OF INTERMEDIATE RESOURCE VALUE AND HAVE A 50-FOOT FRESHWATER WETLAND TRANSITION AREA BUFFER. THE STATE OF NEW JERSEY HAS DETERMINED THAT ALL OR A PORTION OF THIS LOT LIES IN A FLOOD HAZARD AREA AND/OR RIPARIAN ZONE. CERTAIN ACTIVITIES IN FLOOD HAZARD AREAS AND RIPARIAN ZONES ARE REGULATED BY THE NEW JERSEY DEPARTMENT OF ENVIRONMENTAL PROTECTION AND SOME ACTIVITIES MAY BE PROHIBITED ON THIS SITE OR MAY FIRST REQUIRE A FLOOD HAZARD AREA PERMIT. CONTACT THE WATERSHED AND LAND MANAGEMENT PROGRAM AT (609) 777-0454 FOR MORE INFORMATION PRIOR TO ANY CONSTRUCTION ON-SITE.
- THE FLOOD HAZARD ELEVATION FOR THE PROJECT SITE WAS DETERMINED USING METHOD 3, THE FEMA FLUMINAL METHOD, AS SET FORTH IN N.J.A.C. 7:13 FLOOD HAZARD AREA CONTROL ACT RULES. THE NEW JERSEY FLOOD HAZARD AREA DESIGN FLOOD (NFHAD) FOR THE PROJECT SITE HAS BEEN DETERMINED TO BE ELEVATION 72.4 NAVD 88.

DRAINAGE PIPE INSTALLATION WITHIN WETLAND TRANSITION AREA NOTES:

- THE PROPOSED 36" DIA. HDPE DRAINAGE PIPE FROM PROPOSED DRAINAGE MANHOLE MH1-9 TO THE EXISTING DRAINAGE MANHOLE LOCATED WITHIN THE WETLAND TRANSITION AREA SHALL BE INSTALLED USING HORIZONTAL DIRECTIONAL DRILLING (HDD) FOR THE LENGTH OF PROPOSED PIPE LOCATED WITHIN THE WETLAND TRANSITION AREA, IN ORDER TO AVOID SOIL DISTURBANCE AND IMPACTS TO THE WETLAND TRANSITION AREA.

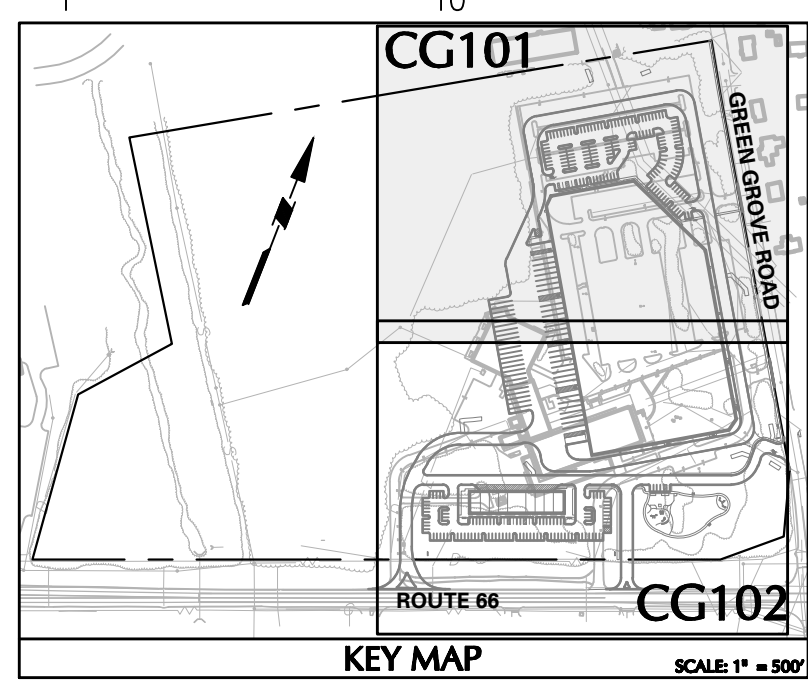
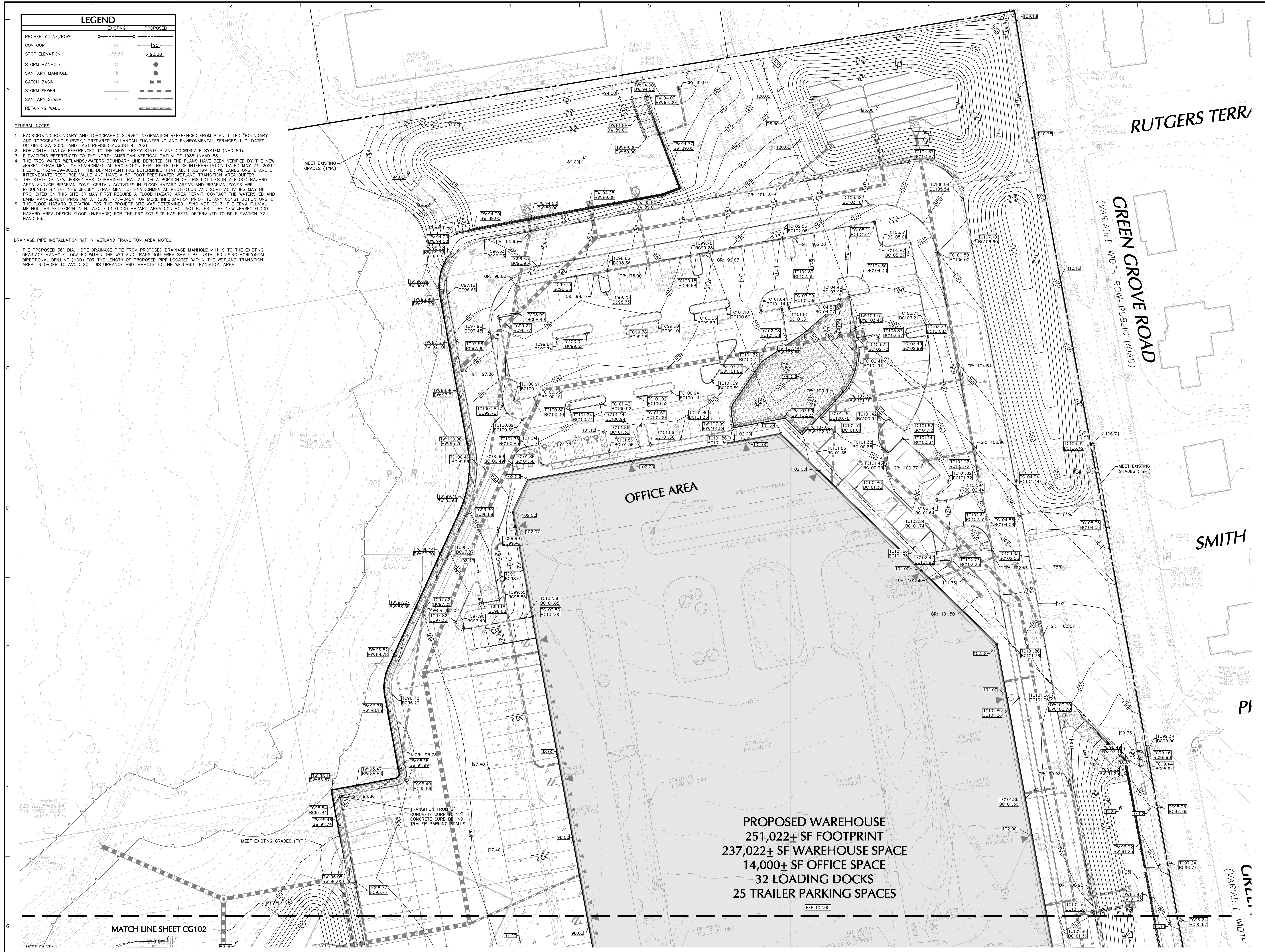

Date	Description	No.
5/3/24	REVISED FOR SUBMISSION TO NEPTUNE	4
8/30/23	REVISED PER NJDEP COMMENTS	3
7/28/23	REVISED PER NJDOT, NJDEP, & FIRST ENERGY COMMENTS	2
5/10/23	REVISED RETAIL LAYOUT & PER NJDOT COMMENTS	1

REVISIONS

SIGNATURE: *John Cote* DATE SIGNED: 5/3/2024
 PROFESSIONAL ENGINEER NJ Lic. No. 246E03705800

LANGAN
 Langan Engineering and Environmental Services, LLC
 300 Kimball Drive
 Parsippany, NJ 07054
 T: 973.560.4900 F: 973.560.4901 www.langan.com
 NJ Certificate of Authorization No. 246A27866400

Project: **3501 STATE ROUTE 66 REDEVELOPMENT**
 BLOCK No. 3903, LOT No. 12 & 13
 NEPTUNE TOWNSHIP
 MONMOUTH COUNTY NEW JERSEY

Drawing Title: **PARTIAL GRADING PLAN**
CG101

Project No.	Drawing No.
100775002	CG101
Date	Drawn By
AUGUST 26, 2022	TEG
Checked By	Sheet 20 of 48
MJV	

PROPOSED WAREHOUSE
 251,022± SF FOOTPRINT
 237,022± SF WAREHOUSE SPACE
 14,000± SF OFFICE SPACE
 32 LOADING DOCKS
 25 TRAILER PARKING SPACES

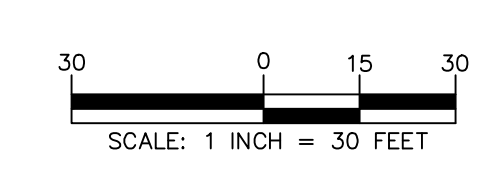

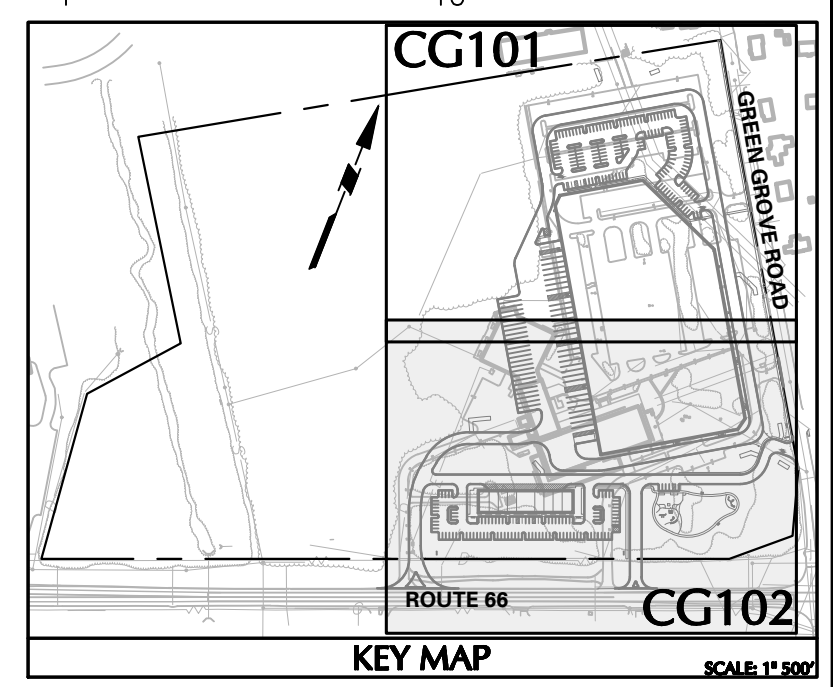
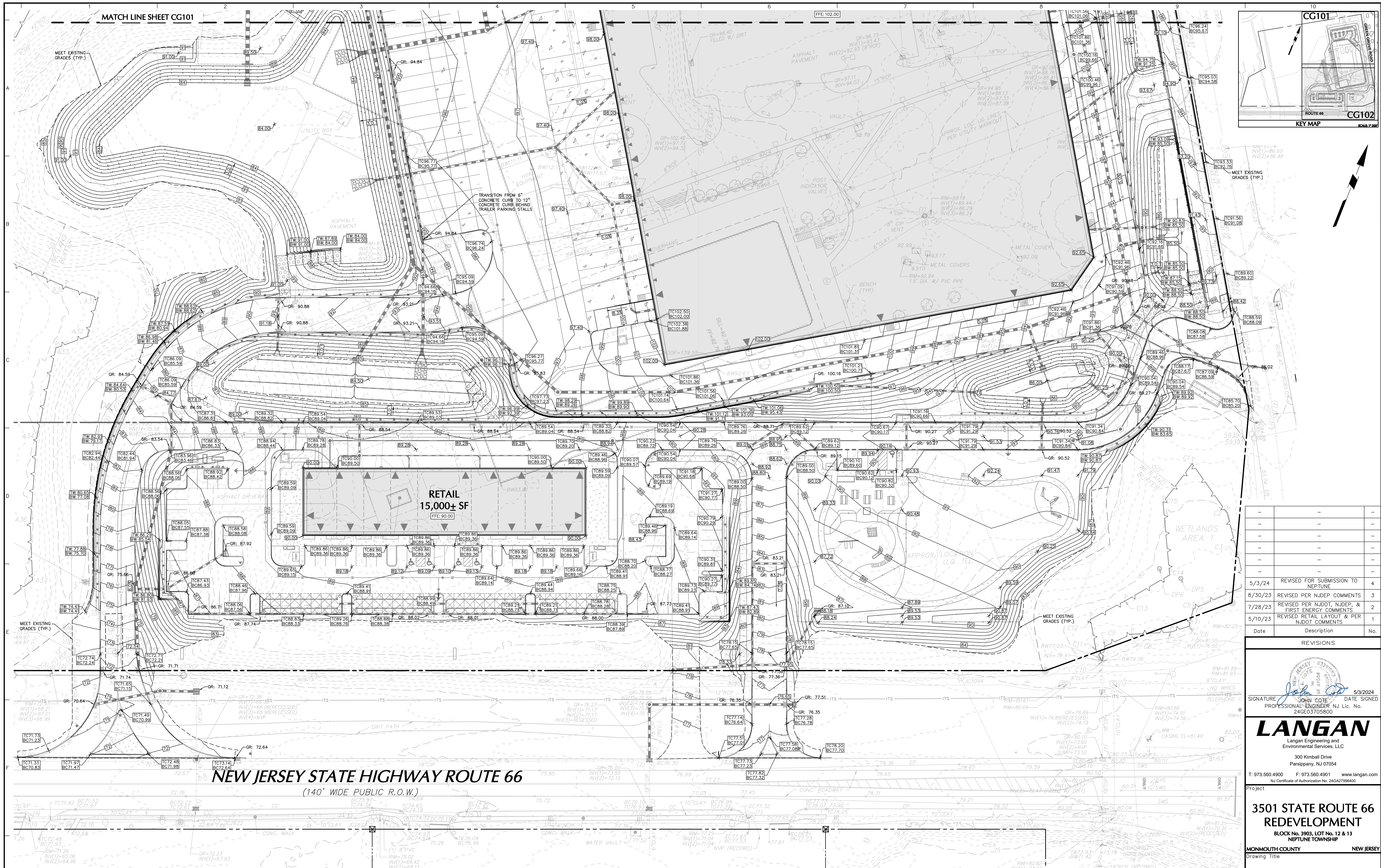

Date	Description	No.
5/3/24	REVISED FOR SUBMISSION TO NEPTUNE	4
8/30/23	REVISED PER NJDEP COMMENTS	3
7/28/23	REVISED PER NJDOT, NJDEP, & FIRST ENERGY COMMENTS	2
5/10/23	REVISED RETAIL LAYOUT & PER NJDOT COMMENTS	1

REVISIONS

SIGNATURE: *John Cote* DATE SIGNED: 5/3/2024
 PROFESSIONAL ENGINEER NJ Lic. No. 246E03705800

LANGAN
 Langan Engineering and Environmental Services, LLC
 300 Kimball Drive
 Parsippany, NJ 07054
 T: 973.560.4900 F: 973.560.4901 www.langan.com
 NJ Certificate of Authorization No. 246A27966403

3501 STATE ROUTE 66 REDEVELOPMENT
 BLOCK No. 3903, LOT No. 12 & 13
 NEPTUNE TOWNSHIP
 MONMOUTH COUNTY NEW JERSEY
 Drawing Title

PARTIAL GRADING PLAN

Project No. 100775002 Drawing No. CG102
 Date: AUGUST 26, 2022
 Drawn By: TEG
 Checked By: MV
 Sheet 21 of 48

LEGEND

PROPERTY	EXISTING	PROPOSED
PROPERTY LINE/ROW	—	—
CONTOUR	90	95
SPOT ELEVATION	× 88.53	● 92.08
STORM MANHOLE	○	●
SANITARY MANHOLE	○	●
CATCH BASIN	○	●
STORM SEWER	—	—
SANITARY SEWER	—	—
RETAINING WALL	—	—

GENERAL NOTES:

- BACKGROUND BOUNDARY AND TOPOGRAPHIC SURVEY INFORMATION REFERENCED FROM PLAN TITLED "BOUNDARY AND TOPOGRAPHIC SURVEY" PREPARED BY LANGAN ENGINEERING AND ENVIRONMENTAL SERVICES, LLC, DATED OCTOBER 27, 2020, AND LAST REVISED AUGUST 4, 2021.
- HORIZONTAL DATUM REFERENCED TO THE NEW JERSEY STATE PLANE COORDINATE SYSTEM (NAD 83).
- ELEVATIONS REFERENCED TO THE NORTH AMERICAN VERTICAL DATUM OF 1988 (NAVD 88).
- THE FRESHWATER WETLANDS/WATERS BOUNDARY LINE DEPICTED ON THE PLANS HAVE BEEN VERIFIED BY THE NEW JERSEY DEPARTMENT OF ENVIRONMENTAL PROTECTION PER THE LETTER OF INTERPRETATION DATED MAY 24, 2021, FILE NO. 1334-09-0002.1. THE DEPARTMENT HAS DETERMINED THAT ALL FRESHWATER WETLANDS ON-SITE ARE OF INTERMEDIATE RESOURCE VALUE AND HAVE A 50-FOOT FRESHWATER WETLAND TRANSITION AREA BUFFER.
- THE STATE OF NEW JERSEY HAS DETERMINED THAT ALL OR A PORTION OF THIS LOT LIES IN A FLOOD HAZARD AREA AND/OR RIPARIAN ZONE. CERTAIN ACTIVITIES IN FLOOD HAZARD AREAS AND RIPARIAN ZONES ARE REGULATED BY THE NEW JERSEY DEPARTMENT OF ENVIRONMENTAL PROTECTION AND SOME ACTIVITIES MAY BE PROHIBITED ON THIS SITE OR MAY FIRST REQUIRE A FLOOD HAZARD AREA PERMIT. CONTACT THE WATERSHED AND LAND MANAGEMENT PROGRAM AT (609) 777-0454 FOR MORE INFORMATION PRIOR TO ANY CONSTRUCTION ON-SITE.
- THE FLOOD HAZARD ELEVATION FOR THE PROJECT SITE WAS DETERMINED USING METHOD 3, THE FEMA FLUVIAL HAZARD AREA DESIGN FLOOD (NUPHAD) FOR THE PROJECT SITE HAS BEEN DETERMINED TO BE ELEVATION 72.4 NAVD 88.

DRAINAGE PIPE INSTALLATION WITHIN WETLAND TRANSITION AREA NOTES:

- THE PROPOSED 36" DIA. HDPE DRAINAGE PIPE FROM PROPOSED DRAINAGE MANHOLE MH-9 TO THE EXISTING DRAINAGE MANHOLE LOCATED WITHIN THE WETLAND TRANSITION AREA SHALL BE INSTALLED USING HORIZONTAL DIRECTIONAL DRILLING (HDD) FOR THE LENGTH OF PROPOSED PIPE LOCATED WITHIN THE WETLAND TRANSITION AREA, IN ORDER TO AVOID SOIL DISTURBANCE AND IMPACTS TO THE WETLAND TRANSITION AREA.

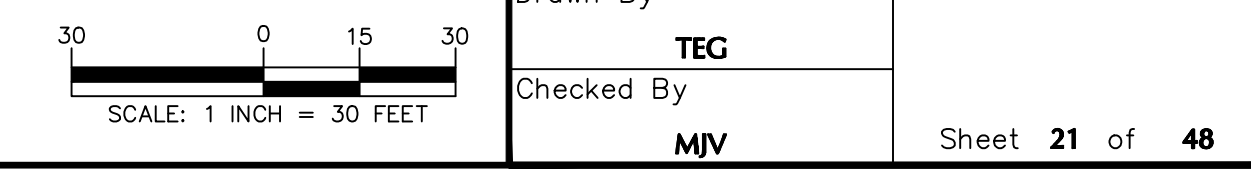

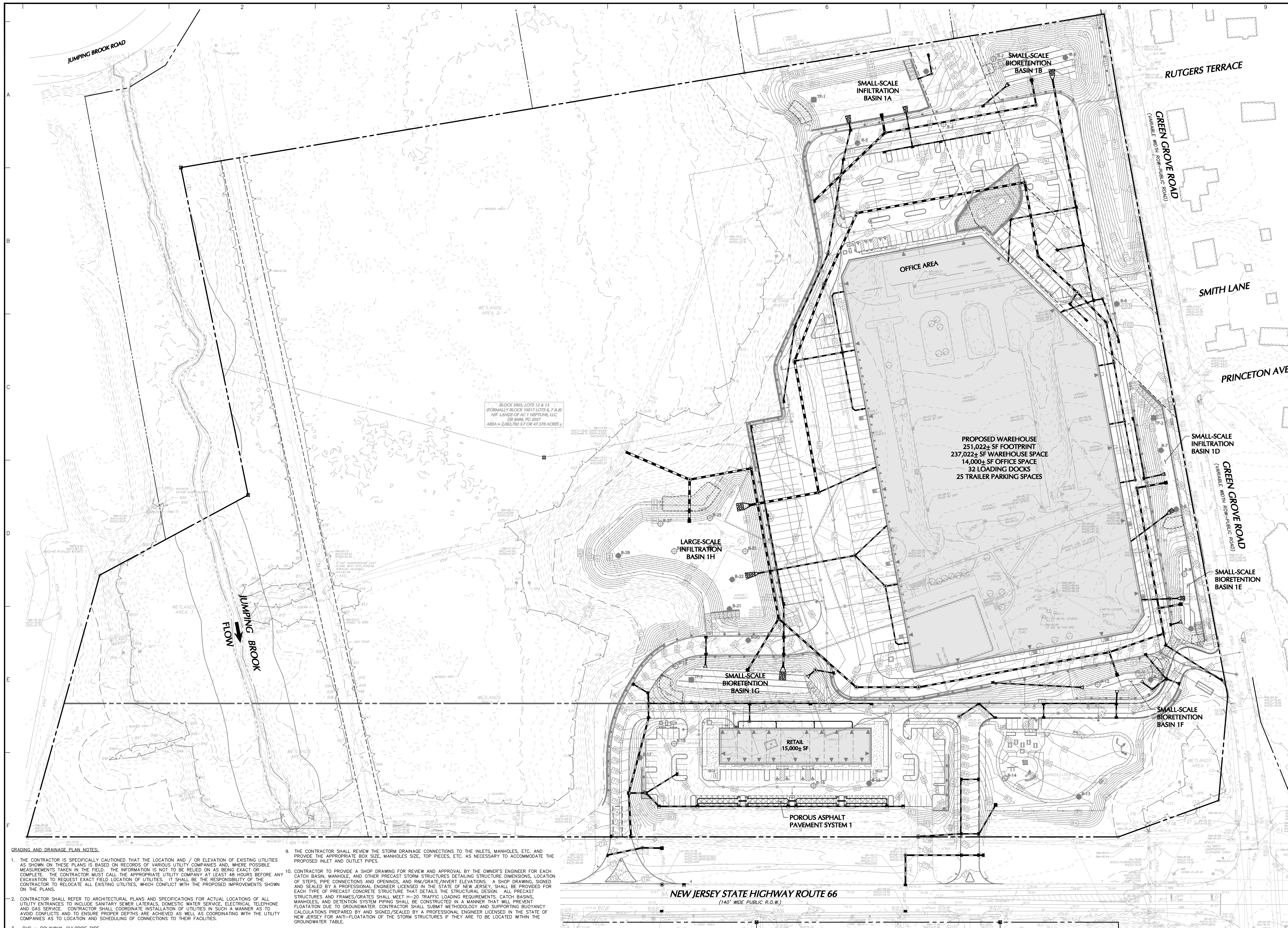

	LEGEND	
	EXISTING	PROPOSED
PROPERTY LINE/ROW	---	---
CONTOUR	--- 90 ---	--- 95 ---
SPOT ELEVATION	• 88.53	• 92.08
STORM MANHOLE	○	●
SANITARY MANHOLE	○	●
CATCH BASIN	□	■
STORM SEWER	---	---
SANITARY SEWER	---	---
RETAINING WALL	---	---

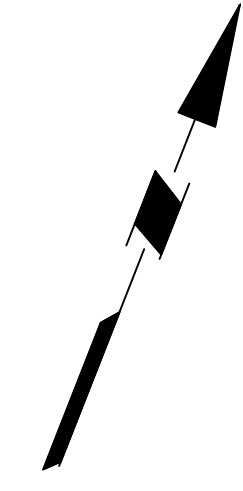

BLOCK 3903, LOTS 12 & 13
FORMERLY BLOCK 10017 LOTS 6, 7 & 8
NEE LANDS OF ACT 1 NEPTUNE, LLC
D# 8668, PG 2017
AREA = 2,265,792 S.F. OR 51.376 ACRES

PROPOSED WAREHOUSE
251,022± SF FOOTPRINT
237,022± SF WAREHOUSE SPACE
14,000± SF OFFICE SPACE
32 LOADING DOCKS
25 TRAILER PARKING SPACES

LARGE-SCALE INFILTRATION BASIN 1H

SMALL-SCALE BIORETENTION BASIN 1G

RETAIL
15,000± SF

POROUS ASPHALT PAVEMENT SYSTEM 1

SMALL-SCALE INFILTRATION BASIN 1D

SMALL-SCALE BIORETENTION BASIN 1E

SMALL-SCALE BIORETENTION BASIN 1F

- GRADING AND DRAINAGE PLAN NOTES:**
- THE CONTRACTOR IS SPECIFICALLY CAUTIONED THAT THE LOCATION AND / OR ELEVATION OF EXISTING UTILITIES AS SHOWN ON THESE PLANS IS BASED ON RECORDS OF VARIOUS UTILITY COMPANIES AND, WHERE POSSIBLE, MEASUREMENTS TAKEN IN THE FIELD. THE INFORMATION IS NOT TO BE RELIED ON AS BEING EXACT OR COMPLETE. THE CONTRACTOR MUST CALL THE APPROPRIATE UTILITY COMPANY AT LEAST 48 HOURS BEFORE ANY EXCAVATION TO REQUEST EXACT FIELD LOCATION OF UTILITIES. IT SHALL BE THE RESPONSIBILITY OF THE CONTRACTOR TO RELOCATE ALL EXISTING UTILITIES, WHICH CONFLICT WITH THE PROPOSED IMPROVEMENTS SHOWN ON THE PLANS.
 - CONTRACTOR SHALL REFER TO ARCHITECTURAL PLANS AND SPECIFICATIONS FOR ACTUAL LOCATIONS OF ALL UTILITY ENTRANCES TO INCLUDE SANITARY SEWER LATERALS, DOMESTIC WATER SERVICE, ELECTRICAL TELEPHONE AND GAS SERVICE. CONTRACTOR SHALL COORDINATE INSTALLATION OF UTILITIES IN SUCH A MANNER AS TO AVOID CONFLICTS AND TO ENSURE PROPER DEPTHS ARE ACHIEVED AS WELL AS COORDINATING WITH THE UTILITY COMPANIES AS TO LOCATION AND SCHEDULING OF CONNECTIONS TO THEIR FACILITIES.
 - PVC = POLYVINYL CHLORIDE PIPE
HDPE = HIGH DENSITY POLYETHYLENE PIPE
RCP = REINFORCED CONCRETE PIPE
 - STORM DRAINAGE PIPING TO UTILIZE WATER TIGHT JOINTS.
 - COMPACTION CRITERIA FOR FILL PLACEMENT IN THE FOLLOWING AREAS SHALL MEET OR EXCEED THE FOLLOWING MINIMUM PERCENTAGE OF MAXIMUM MODIFIED PROCTOR DRY DENSITY AS DETERMINED BY ASTM D-1557 USED ON REPRESENTATIVE SOIL SAMPLES, UNLESS MORE STRINGENT CRITERIA GIVEN ELSEWHERE:

FILL AREA	PERCENT OF MAXIMUM MODIFIED PROCTOR DRY DENSITY
BUILDING FOOTPRINT	95%
PAVEMENT AND ROADWAYS	98%
SIDEWALKS	95%
LANDSCAPE AREAS	90%
TRENCH BACKFILL	95%
 - PROTECT SUBGRADE FROM EXCESSIVE WHEEL LOADING DURING CONSTRUCTION, INCLUDING CONCRETE TRUCKS AND DUMP TRUCKS.
 - REMOVE AREAS OF FINISHED SUBGRADE FOUND TO HAVE INSUFFICIENT COMPACTION DENSITY TO DEPTH NECESSARY AND REPLACE IN A MANNER THAT WILL COMPLY WITH COMPACTION REQUIREMENTS BY USE OF MATERIAL EQUAL TO OR BETTER THAN BEST SUBGRADE MATERIAL ON-SITE. SURFACE OF SUBGRADE AFTER COMPACTION SHALL BE HARD, UNIFORM, SMOOTH, STABLE, AND TRUE TO GRADE AND CROSS SECTION.
 - ALL CONCRETE, UNLESS OTHERWISE NOTED OR SPECIFIED BY REGULATORY AUTHORITIES, SHALL BE A MINIMUM OF 4,000 PSI.
 - THE CONTRACTOR SHALL REVIEW THE STORM DRAINAGE CONNECTIONS TO THE INLETS, MANHOLES, ETC. AND PROVIDE THE APPROPRIATE BOX SIZE, MANHOLES SIZE, TOP PIECES, ETC. AS NECESSARY TO ACCOMMODATE THE PROPOSED INLET AND OUTLET PIPES.
 - CONTRACTOR TO PROVIDE A SHOP DRAWING FOR REVIEW AND APPROVAL BY THE OWNER'S ENGINEER FOR EACH CATCH BASIN, MANHOLE, AND OTHER PRECAST STORM STRUCTURES DETAILING STRUCTURE DIMENSIONS, LOCATION OF STEPS, PIPE CONNECTIONS AND OPENINGS, AND RIM/GRATE/INVERT ELEVATIONS. A SHOP DRAWING, SIGNED AND SEALED BY A PROFESSIONAL ENGINEER LICENSED IN THE STATE OF NEW JERSEY, SHALL BE PROVIDED FOR EACH TYPE OF PRECAST CONCRETE STRUCTURE THAT DETAILS THE STRUCTURAL DESIGN. CALL PRECAST STRUCTURES AND FRAMES/GRATES SHALL MEET H-20 TRAFFIC LOADING REQUIREMENTS. CATCH BASINS, MANHOLES, AND DETENTION SYSTEM PIPING SHALL BE CONSTRUCTED IN A MANNER THAT WILL PREVENT FLOATION DUE TO GROUNDWATER. CONTRACTOR SHALL SUBMIT METHODOLOGY AND SUPPORTING BUOYANCY CALCULATIONS PREPARED BY AND SIGNED/SEALED BY A PROFESSIONAL ENGINEER LICENSED IN THE STATE OF NEW JERSEY FOR ANTI-FLOATION OF THE STORM STRUCTURES IF THEY ARE TO BE LOCATED WITHIN THE GROUNDWATER TABLE.
 - THE CONTRACTOR SHALL PROVIDE A RETAINING WALL DESIGN FOR EACH PROPOSED WALL PREPARED BY A PROFESSIONAL ENGINEER LICENSED IN THE STATE OF NEW JERSEY FOR REVIEW BY THE OWNER'S ENGINEER PRIOR TO INSTALLATION. THE CONTRACTOR AND THE RETAINING WALL DESIGNER SHALL SPECIFICALLY NOTE ANY EXISTING OR PROPOSED STRUCTURES THAT ARE LOCATED IN OR NEAR THE WALL (INLETS, LIGHT POLES, FENCES, STORM PIPES, UTILITIES, GUIDE RAILS, AND OTHER FEATURES) AND SHALL COORDINATE DESIGN AND INSTALLATION OF RETAINING WALL SUCH THAT THE FEATURES ARE ACCOMMODATED IN THE DESIGN AS APPROPRIATE.
 - PIPE LENGTHS PROVIDED ARE MEASURED FROM CENTER OF STRUCTURE TO CENTER OF STRUCTURE.
 - CONTRACTOR SHALL CLEAR EXISTING STORM PIPES OF ANY DEBRIS OR SEDIMENT.
 - TRENCH DEPTH REQUIREMENTS MEASURED FROM FINISHED GRADE OR PAVED SURFACE SHALL MEET THE FOLLOWING REQUIREMENTS OR APPLICABLE CODES AND ORDINANCES:
 - SANITARY SEWER: DEPTHS, ELEVATIONS AND GRADES AS INDICATED ON DRAWINGS.
 - STORM SEWER: DEPTHS, ELEVATIONS, AND GRADES AS SHOWN ON DRAWINGS.
 - ELECTRICAL CONDUITS: 24 INCHES MINIMUM TO TOP OF CONDUIT OR AS REQUIRED BY NEC 300-5, NEC 710-36 CODES, OR THE LOCAL UTILITY COMPANY REQUIREMENTS, WHICHEVER IS DEEPER.
 - TV CONDUITS: 18 INCHES MINIMUM TO TOP OF CONDUIT OR AS REQUIRED BY THE LOCAL UTILITY COMPANY, WHICHEVER IS DEEPER.
 - TELEPHONE CONDUITS: 18 INCHES MINIMUM TO TOP OF CONDUIT OR AS REQUIRED BY THE LOCAL UTILITY COMPANY, WHICHEVER IS DEEPER.

- f. GAS MAINS AND SERVICE: 30 INCHES MINIMUM TO TOP OF PIPE, OR AS REQUIRED BY THE LOCAL UTILITY COMPANY, WHICHEVER IS DEEPER.
15. SITE GRADING SHALL NOT PROCEED UNTIL ALL EROSION CONTROL MEASURES HAVE BEEN INSTALLED.
16. CONTRACTOR SHALL PROVIDE WRITTEN REQUESTS FOR INFORMATION TO THE OWNER AND OWNER'S ENGINEER PRIOR TO THE CONSTRUCTION OF ANY SPECIFIC SITEWORK ITEM IF ANY SPECIFIC SITEWORK ITEM DEPICTED ON THE PLANS WARRANTS ADDITIONAL INFORMATION REQUIRED FOR CONSTRUCTION AND IS NOT RELATED TO MEANS AND METHODS OF CONSTRUCTION. THE CONTRACTOR SHALL BE RESPONSIBLE FOR SPECIFIC SITE WORK ITEMS INSTALLED DIFFERENTLY THAN INTENDED AS DEPICTED ON THE PLANS IN THE ABSENCE OF SUBMITTING AND ADDRESSING WRITTEN REQUESTS FOR INFORMATION.
17. PROPOSED SIDEWALKS SHALL BE CONSTRUCTED WITH CROSS-SLOPES THAT DO NOT EXCEED 1.5%.
18. PROPOSED RCP PIPE IS TO BE CLASS V PIPE.
- DRAINAGE PIPE INSTALLATION WITHIN WETLAND TRANSITION AREA NOTES:**
- THE PROPOSED 36" DIA. HDPE DRAINAGE PIPE FROM PROPOSED DRAINAGE MANHOLE MH1-9 TO THE EXISTING DRAINAGE MANHOLE LOCATED WITHIN THE WETLAND TRANSITION AREA SHALL BE INSTALLED USING HORIZONTAL DIRECTIONAL DRILLING (HDD) FOR THE LENGTH OF PROPOSED PIPE LOCATED WITHIN THE WETLAND TRANSITION AREA, IN ORDER TO AVOID SOIL DISTURBANCE AND IMPACTS TO THE WETLAND TRANSITION AREA.

- GENERAL NOTES:**
- BACKGROUND BOUNDARY AND TOPOGRAPHIC SURVEY INFORMATION REFERENCED FROM PLAN TITLED "BOUNDARY AND TOPOGRAPHIC SURVEY," PREPARED BY LANGAN ENGINEERING AND ENVIRONMENTAL SERVICES, LLC, DATED OCTOBER 21, 2020, AND LAST REVISED AUGUST 4, 2021.
 - HORIZONTAL DATUM REFERENCED TO THE NEW JERSEY STATE PLANE COORDINATE SYSTEM (NAD 83).
 - ELEVATIONS REFERENCED TO THE NORTH AMERICAN VERTICAL DATUM OF 1988 (NAVD 88).
 - THE FRESHWATER WETLANDS/WATERS BOUNDARY LINE DEPICTED ON THE PLANS HAVE BEEN VERIFIED BY THE NEW JERSEY DEPARTMENT OF ENVIRONMENTAL PROTECTION PER THE LETTER OF INTERPRETATION DATED MAY 24, 2021, FILE NO. 1334-01-00021. THE DEPARTMENT HAS DETERMINED THAT ALL FRESHWATER WETLANDS ON-SITE ARE OF INTERMEDIATE RESOURCE VALUE AND HAVE A 50-FOOT FRESHWATER WETLAND TRANSITION AREA BUFFER.
 - THE STATE OF NEW JERSEY HAS DETERMINED THAT ALL OR A PORTION OF THIS LOT LIES IN A FLOOD HAZARD AREA AND/OR RIPARIAN ZONE. CERTAIN ACTIVITIES IN FLOOD HAZARD AREAS AND RIPARIAN ZONES ARE REGULATED BY THE NEW JERSEY DEPARTMENT OF ENVIRONMENTAL PROTECTION AND SOME ACTIVITIES MAY BE PROHIBITED ON THIS SITE OR MAY FIRST REQUIRE A FLOOD HAZARD AREA PERMIT. CONTACT THE WATERSHED AND LAND MANAGEMENT PROGRAM AT (609) 777-0454 FOR MORE INFORMATION PRIOR TO ANY CONSTRUCTION ON-SITE.
 - THE FLOOD HAZARD ELEVATION FOR THE PROJECT SITE WAS DETERMINED USING METHOD 3, THE FEMA FLUVIAL METHOD, AS SET FORTH IN N.J.A.C. 7:13 FLOOD HAZARD AREA CONTROL ACT RULES. THE NEW JERSEY FLOOD HAZARD AREA DESIGN FLOOD (NFHADP) FOR THE PROJECT SITE HAS BEEN DETERMINED TO BE ELEVATION 72.4 NAVD 88.

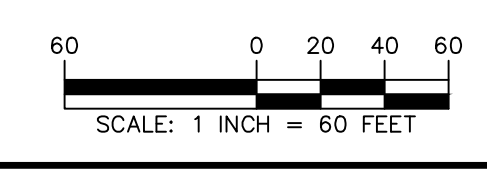

Date	Description	No.
5/3/24	REVISED FOR SUBMISSION TO NEPTUNE	4
8/30/23	REVISED PER NJDEP COMMENTS	3
7/28/23	REVISED PER NJDOT, NJDEP, & FIRST ENERGY COMMENTS	2
5/10/23	REVISED RETAIL LAYOUT & PER NJDOT COMMENTS	1

REVISIONS

SIGNATURE: *John Cote* DATE SIGNED: 5/3/2024
 PROFESSIONAL ENGINEER NJ Lic. No. 246E03705800

LANGAN
 Langan Engineering and Environmental Services, LLC
 300 Kimball Drive
 Parsippany, NJ 07054

T: 973.560.4900 F: 973.560.4901 www.langan.com
 NJ Certificate of Authorization No. 246A27896403

Project: **3501 STATE ROUTE 66 REDEVELOPMENT**
 BLOCK No. 3903, LOT No. 12 & 13
 NEPTUNE TOWNSHIP
 MONMOUTH COUNTY NEW JERSEY

Drawing Title: **OVERALL DRAINAGE PLAN**

Project No.	Drawing No.
100775002	CG103
Date	August 26, 2022
Drawn By	TEG
Checked By	MJV

Sheet 22 of 48

- GENERAL NOTES**
- BACKGROUND BOUNDARY AND TOPOGRAPHIC SURVEY INFORMATION REFERENCED FROM PLAN TITLED "BOUNDARY AND TOPOGRAPHIC SURVEY," PREPARED BY LANGAN ENGINEERING AND ENVIRONMENTAL SERVICES, LLC, DATED OCTOBER 27, 2020, AND LAST REVISED AUGUST 4, 2021.
 - HORIZONTAL DATUM REFERENCED TO THE NEW JERSEY STATE PLANE COORDINATE SYSTEM (NAD 83).
 - ELEVATIONS REFERENCED TO THE NORTH AMERICAN VERTICAL DATUM OF 1988 (NAVD 88).
 - THE FRESHWATER WETLANDS/WATERS BOUNDARY LINE DEPICTED ON THE PLANS HAVE BEEN VERIFIED BY THE NEW JERSEY DEPARTMENT OF ENVIRONMENTAL PROTECTION PER THE LETTER OF INTERPRETATION DATED MAY 24, 2021, FILE NO. 1334-09-00021. THE DEPARTMENT HAS DETERMINED THAT ALL FRESHWATER WETLANDS ON-SITE ARE OF INTERMEDIATE RESOURCE VALUE AND HAVE A 50-FOOT FRESHWATER WETLAND TRANSITION AREA BUFFER.
 - THE STATE OF NEW JERSEY HAS DETERMINED THAT ALL OR A PORTION OF THIS LOT LIES IN A FLOOD HAZARD AREA AND/OR RIPARIAN ZONE. CERTAIN ACTIVITIES IN FLOOD HAZARD AREAS AND RIPARIAN ZONES ARE REGULATED BY THE NEW JERSEY DEPARTMENT OF ENVIRONMENTAL PROTECTION AND SOME ACTIVITIES MAY BE PROHIBITED ON THIS SITE OR MAY FIRST REQUIRE A FLOOD HAZARD AREA PERMIT. CONTACT THE WATERSHED AND LAND MANAGEMENT PROGRAM AT (609) 777-0454 FOR MORE INFORMATION PRIOR TO ANY CONSTRUCTION ON-SITE.
 - THE FLOOD HAZARD ELEVATION FOR THE PROJECT SITE WAS DETERMINED USING METHOD 3, THE FEMA FLOOD MAP METHOD, AS SET FORTH IN N.J.A.C. 7:13 FLOOD HAZARD AREA CONTROL ACT RULES. THE NEW JERSEY FLOOD HAZARD AREA DESIGN FLOOD (NFHAD) FOR THE PROJECT SITE HAS BEEN DETERMINED TO BE ELEVATION 72.4 NAVD 88.

- DRAINAGE PIPE INSTALLATION WITHIN WETLAND TRANSITION AREA NOTES:**
- THE PROPOSED 36" DIA. HDPE DRAINAGE PIPE FROM PROPOSED DRAINAGE MANHOLE MH1-9 TO THE EXISTING DRAINAGE MANHOLE LOCATED WITHIN THE WETLAND TRANSITION AREA SHALL BE INSTALLED USING HORIZONTAL DIRECTIONAL DRILLING (HDD) FOR THE LENGTH OF PROPOSED PIPE LOCATED WITHIN THE WETLAND TRANSITION AREA, IN ORDER TO AVOID SOIL DISTURBANCE AND IMPACTS TO THE WETLAND TRANSITION AREA.

PROPERTY LINE/ROW	LEGEND	
	EXISTING	PROPOSED
CONTOUR	90	95
SPOT ELEVATION	x 88.53	x 92.08
STORM MANHOLE	⊙	⊙
SANITARY MANHOLE	⊙	⊙
CATCH BASIN	⊙	⊙
STORM SEWER	---	---
SANITARY SEWER	---	---
RETAINING WALL	=====	=====

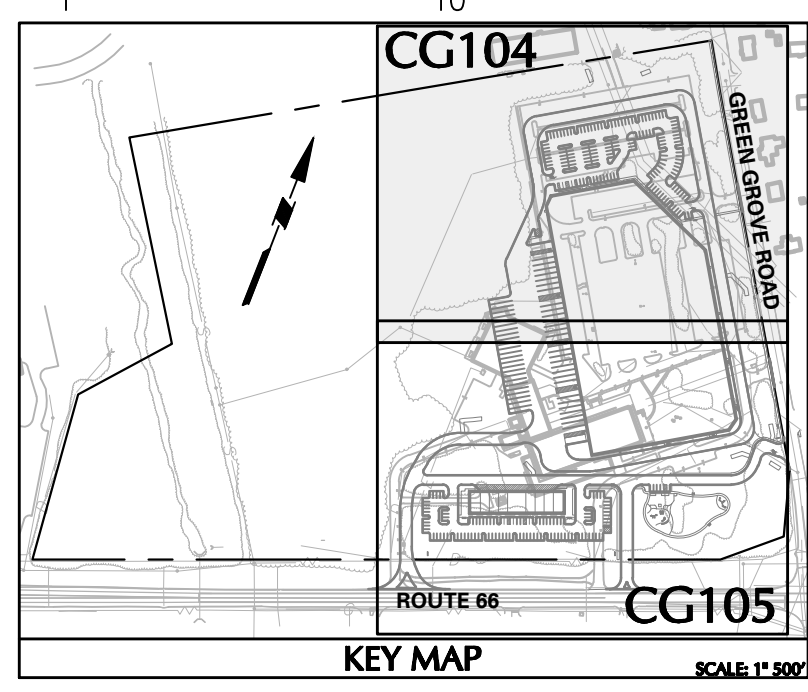
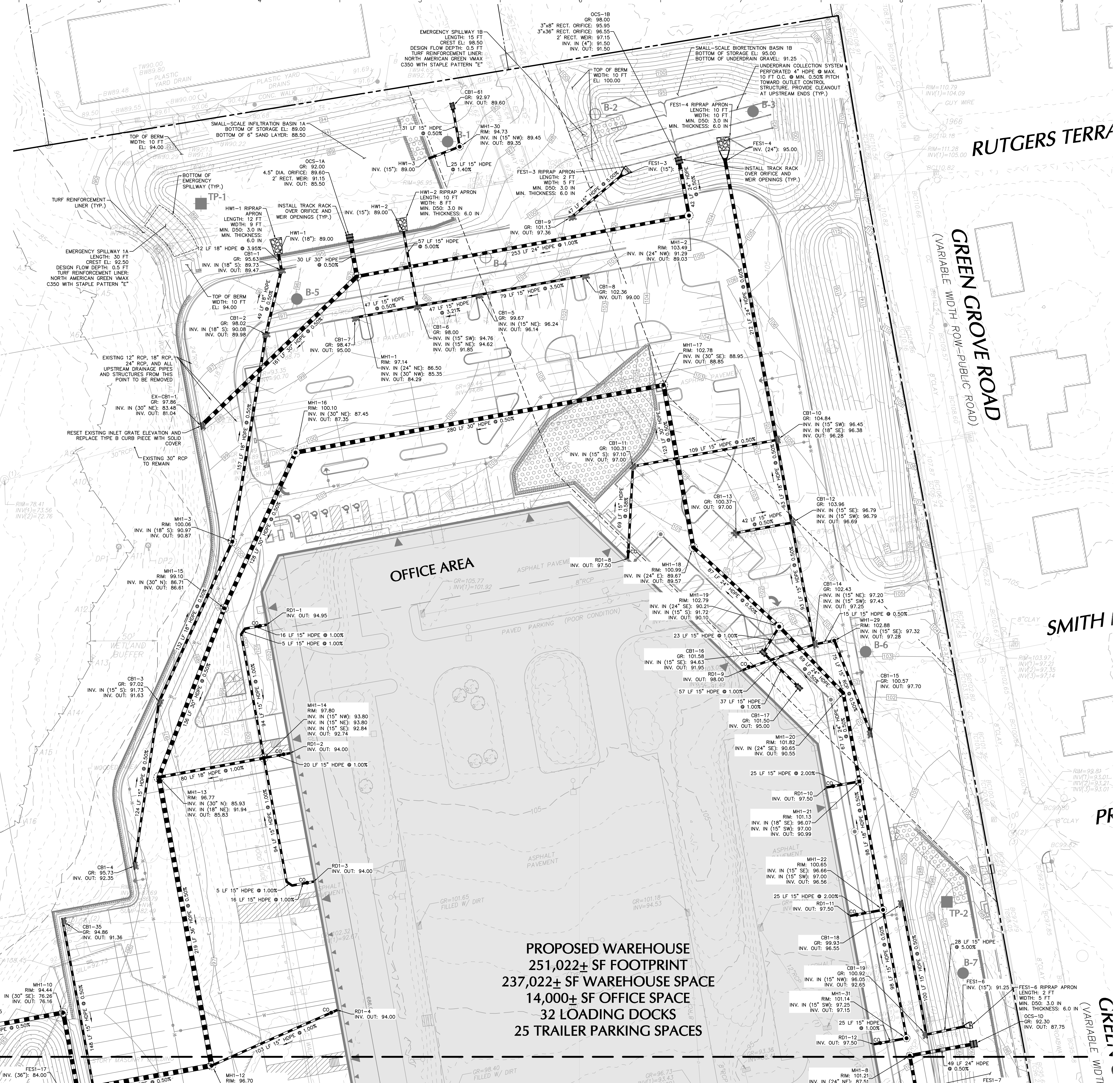

OFFICE AREA

PROPOSED WAREHOUSE
 251,022± SF FOOTPRINT
 237,022± SF WAREHOUSE SPACE
 14,000± SF OFFICE SPACE
 32 LOADING DOCKS
 25 TRAILER PARKING SPACES

Date	Description	No.
5/3/24	REVISED FOR SUBMISSION TO NEPTUNE	4
8/30/23	REVISED PER NJDEP COMMENTS	3
7/28/23	REVISED PER NJDOT, NJDEP, & FIRST ENERGY COMMENTS	2
5/10/23	REVISED RETAIL LAYOUT & PER NJDOT COMMENTS	1

LANGAN
 Langan Engineering and Environmental Services, LLC
 300 Kimball Drive
 Parsippany, NJ 07054
 T: 973.560.4900 F: 973.560.4901 www.langan.com
 NJ Certificate of Authorization No. 24G03705800

3501 STATE ROUTE 66 REDEVELOPMENT
 BLOCK No. 3903, LOT No. 12 & 13
 NEPTUNE TOWNSHIP
 MONMOUTH COUNTY NEW JERSEY

PARTIAL DRAINAGE PLAN

Project No.	100775002	Drawing No.	CG104
Date	AUGUST 26, 2022	Checked By	TEG
Drawn By	TEG	Sheet	23 of 48

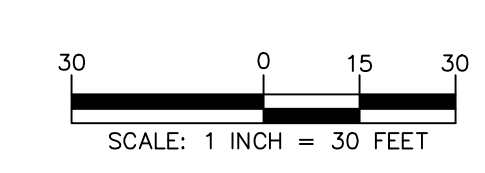

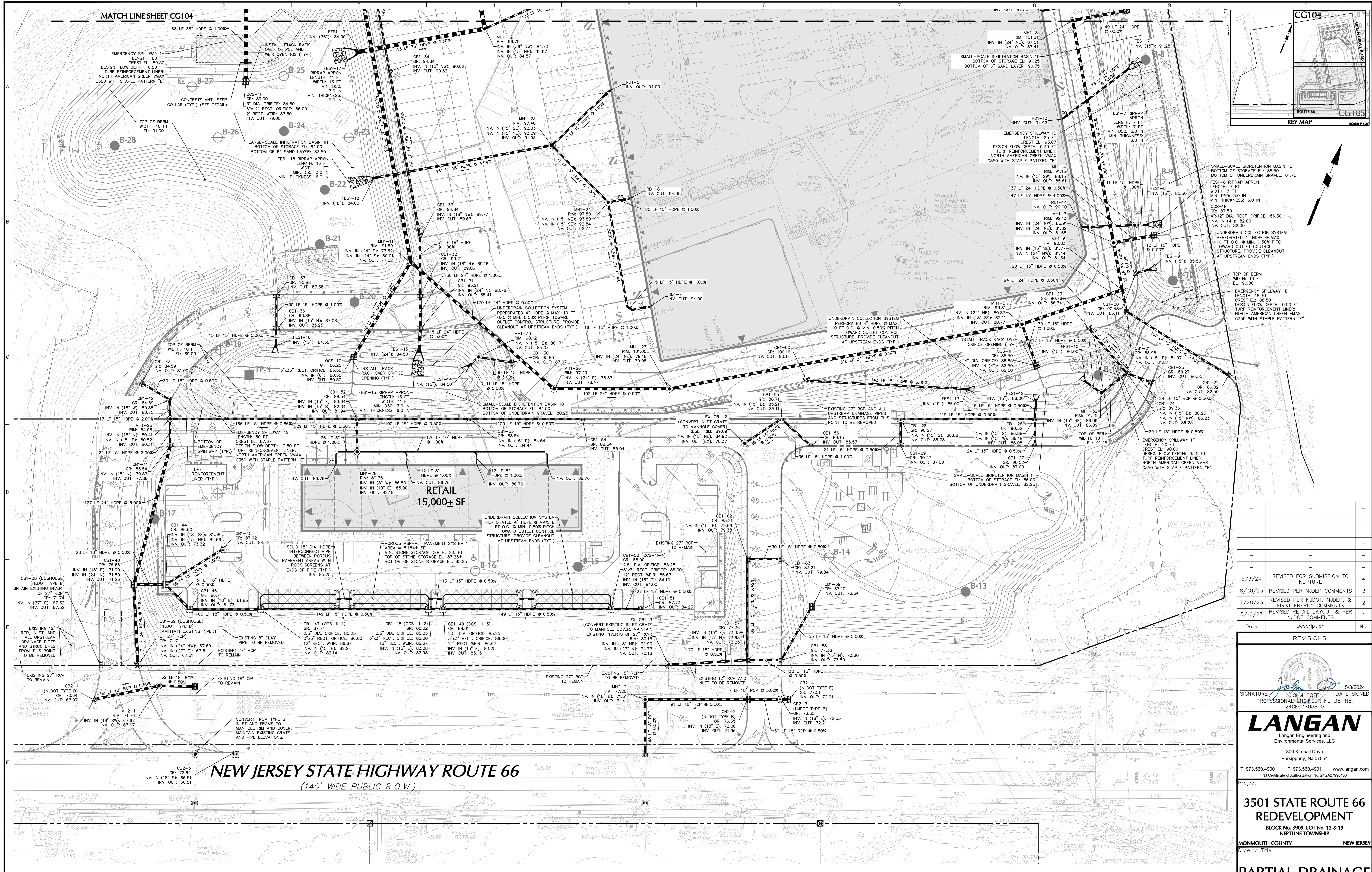

NEW JERSEY STATE HIGHWAY ROUTE 66
(140' WIDE PUBLIC R.O.W.)

LEGEND	
EXISTING	PROPOSED
PROPERTY LINE/ROW	PROPERTY LINE/ROW
CONTOUR	CONTOUR
SPOT ELEVATION	SPOT ELEVATION
STORM MANHOLE	STORM MANHOLE
SANITARY MANHOLE	SANITARY MANHOLE
CATCH BASIN	CATCH BASIN
STORM SEWER	STORM SEWER
SANITARY SEWER	SANITARY SEWER
RETAINING WALL	RETAINING WALL

- GENERAL NOTES:**
- BACKGROUND BOUNDARY AND TOPOGRAPHIC SURVEY INFORMATION REFERENCED FROM PLAN TITLED "BOUNDARY AND TOPOGRAPHIC SURVEY" PREPARED BY LANGAN ENGINEERING AND ENVIRONMENTAL SERVICES, LLC, DATED OCTOBER 27, 2020, AND LAST REVISED AUGUST 4, 2021.
 - HORIZONTAL DATUM REFERENCED TO THE NEW JERSEY STATE PLANE COORDINATE SYSTEM (NAD 83).
 - ELEVATIONS REFERENCED TO THE NORTH AMERICAN VERTICAL DATUM OF 1988 (NAVD 88).
 - THE FRESHWATER WETLANDS/WATERS BOUNDARY LINE DEPICTED ON THE PLANS HAVE BEEN VERIFIED BY THE NEW JERSEY DEPARTMENT OF ENVIRONMENTAL PROTECTION PER THE LETTER OF INTERPRETATION DATED MAY 24, 2021, FILE NO. 1334-09-0021. THE STATE OF NEW JERSEY HAS DETERMINED THAT ALL FRESHWATER WETLANDS ON-SITE ARE OF INTERMEDIATE RESOURCE VALUE AND HAVE A 50-FOOT FRESHWATER WETLAND TRANSITION AREA BUFFER.
 - THE STATE OF NEW JERSEY HAS DETERMINED THAT ALL OR A PORTION OF THIS LOT LIES IN A FLOOD HAZARD AREA AND/OR RIPARIAN ZONE. CERTAIN ACTIVITIES IN FLOOD HAZARD AREAS AND RIPARIAN ZONES ARE REGULATED BY THE NEW JERSEY DEPARTMENT OF ENVIRONMENTAL PROTECTION AND SOME ACTIVITIES MAY BE PROHIBITED ON THIS SITE OR MAY FIRST REQUIRE A FLOOD HAZARD AREA PERMIT. CONTACT THE WATERSHED AND LAND MANAGEMENT PROGRAM AT (609) 777-0454 FOR MORE INFORMATION PRIOR TO ANY CONSTRUCTION ON-SITE.
 - THE FLOOD HAZARD ELEVATION FOR THE PROJECT SITE WAS DETERMINED USING METHOD 1, THE FEMA FLUVIAL METHOD, AS SET FORTH IN N.J.A.C. 7:13 FLOOD HAZARD AREA CONTROL ACT RULES. THE NEW JERSEY FLOOD HAZARD AREA DESIGN FLOW (NFJHDF) FOR THE PROJECT SITE HAS BEEN DETERMINED TO BE ELEVATION 72.4 NAVD 88.

- DRAINAGE PIPE INSTALLATION WITHIN WETLAND TRANSITION AREA NOTES:**
- THE PROPOSED 36" DIA. HDPE DRAINAGE PIPE FROM PROPOSED DRAINAGE MANHOLE MH-9 TO THE EXISTING DRAINAGE MANHOLE LOCATED WITHIN THE WETLAND TRANSITION AREA SHALL BE INSTALLED USING HORIZONTAL DIRECTIONAL DRILLING (HDD) FOR THE LENGTH OF PROPOSED PIPE LOCATED WITHIN THE WETLAND TRANSITION AREA, IN ORDER TO AVOID SOIL DISTURBANCE AND IMPACTS TO THE WETLAND TRANSITION AREA.

Date	Description	No.
5/3/24	REVISED FOR SUBMISSION TO NEPTUNE	4
8/30/23	REVISED PER NJDEP COMMENTS	3
7/28/23	REVISED PER NJDEP, NJDEP & FIRST ENERGY COMMENTS	2
5/10/23	REVISED RETAIL LAYOUT & PER NJDOT COMMENTS	1

REVISIONS

DATE SIGNED: 5/3/2024
 SIGNATURE: JOHN COTE
 PROFESSIONAL ENGINEER NJ Lic. No. 24603705800

LANGAN
 Langan Engineering and Environmental Services, LLC
 300 Kimball Drive
 Parsippany, NJ 07054
 T: 973.560.4900 F: 973.560.4901 www.langan.com
 NJ Certificate of Authorization No. 24603705800

3501 STATE ROUTE 66 REDEVELOPMENT
 BLOCK No. 3903, LOT No. 12 & 13
 NEPTUNE TOWNSHIP
 MONMOUTH COUNTY NEW JERSEY

PARTIAL DRAINAGE PLAN

Project No.	10075002	Drawing No.	CG105
Date	AUGUST 26, 2022	Checked By	TEG
Drawn By	TEG	Sheet	24 of 48

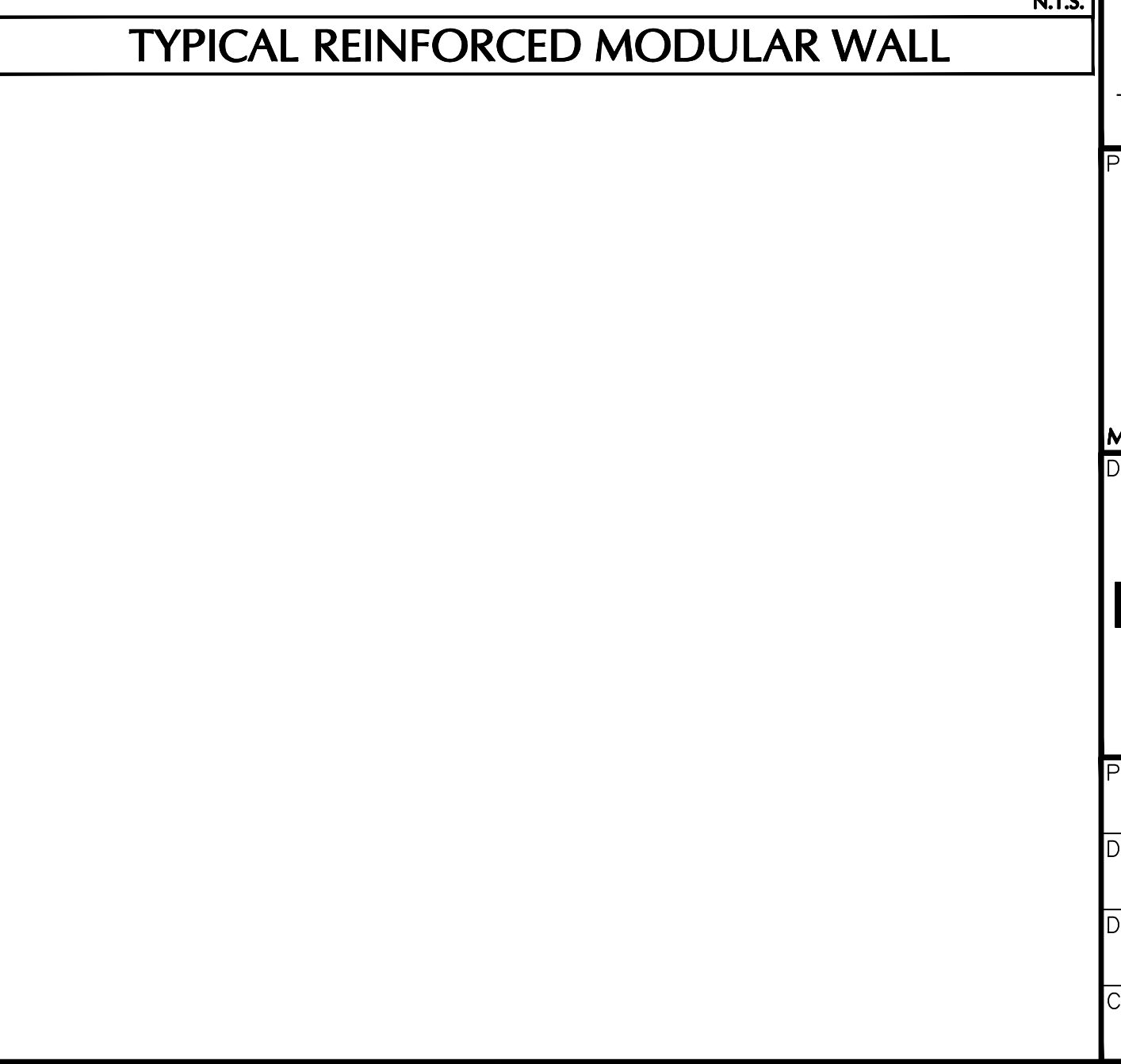
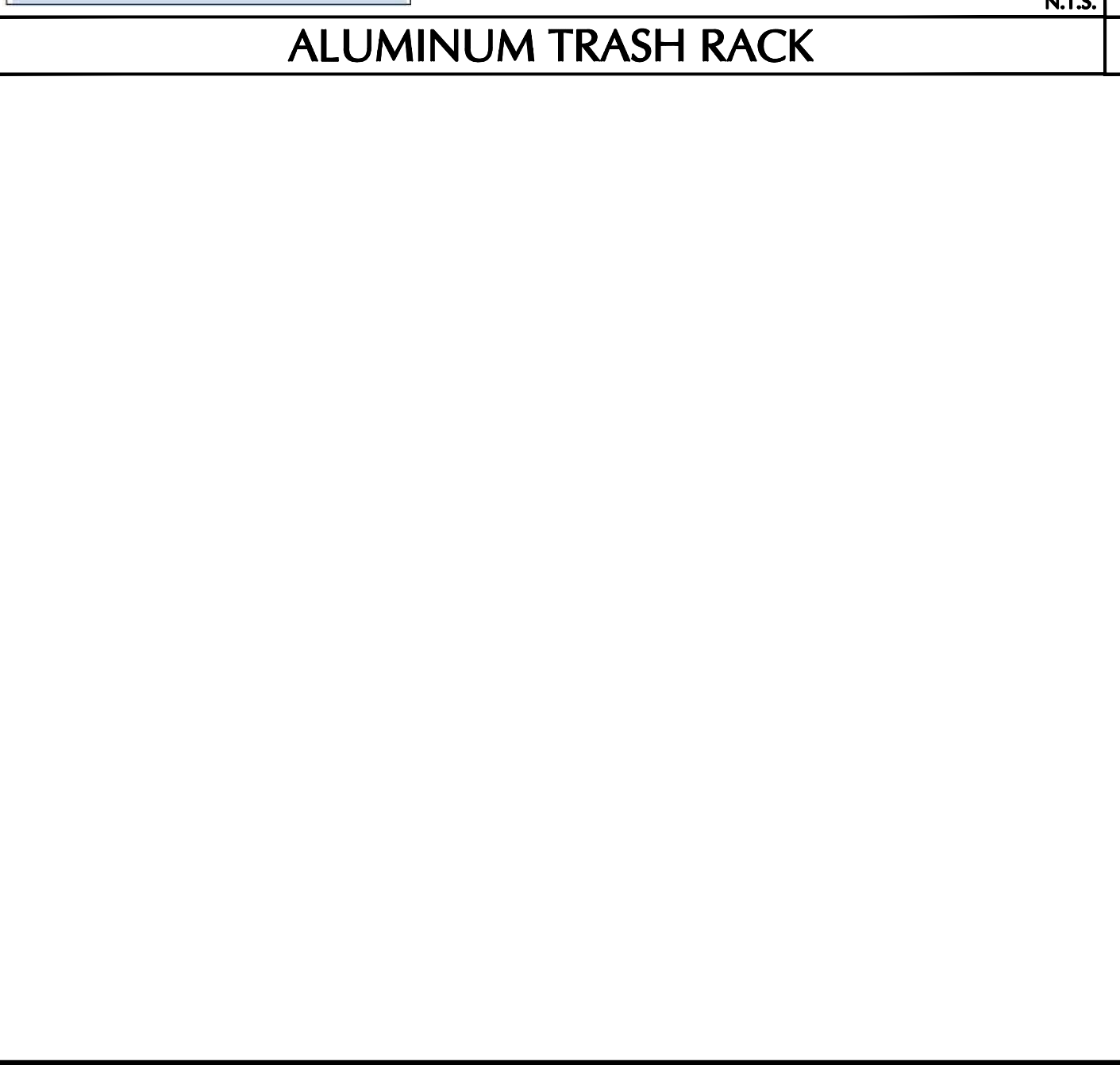
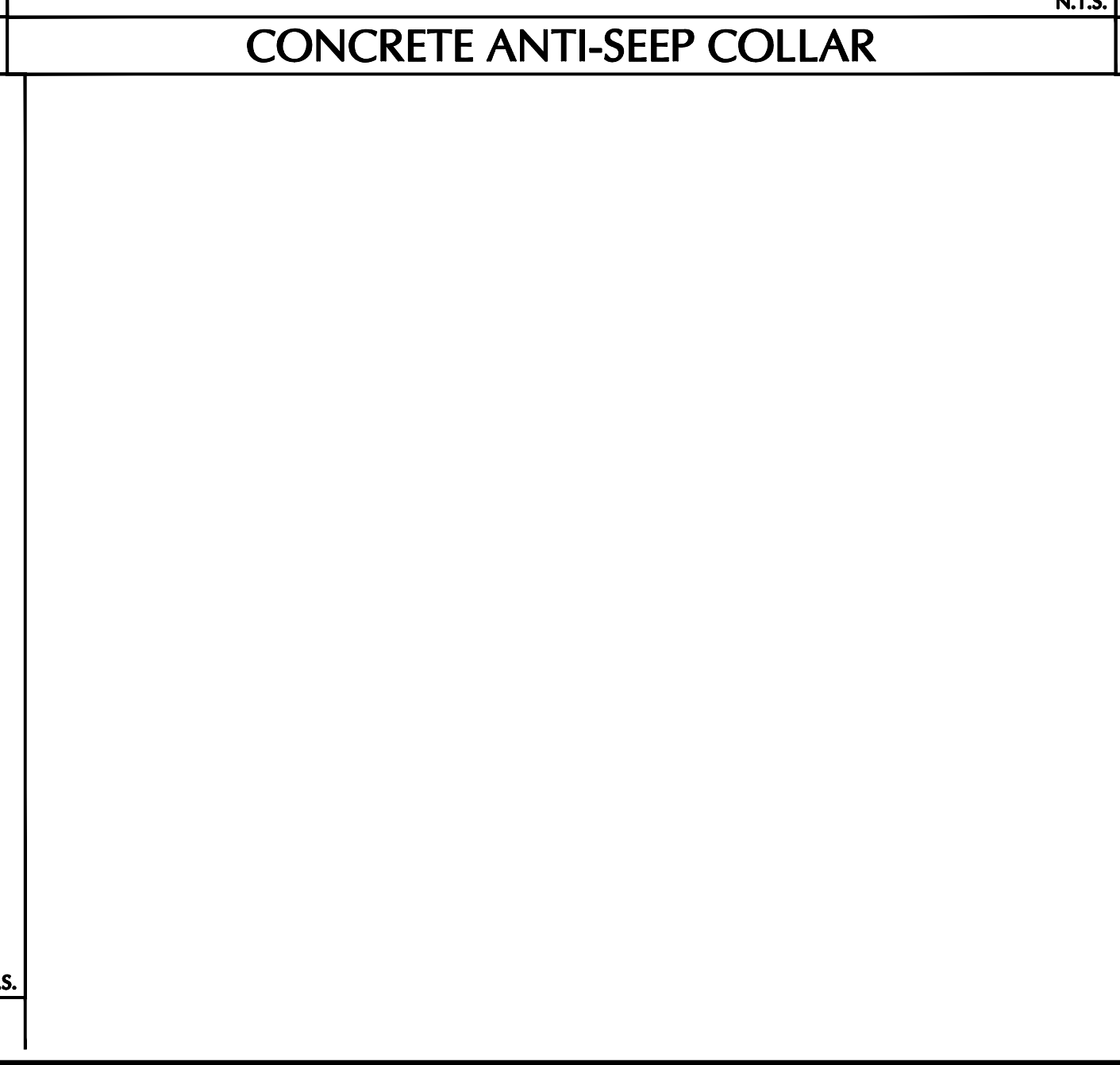
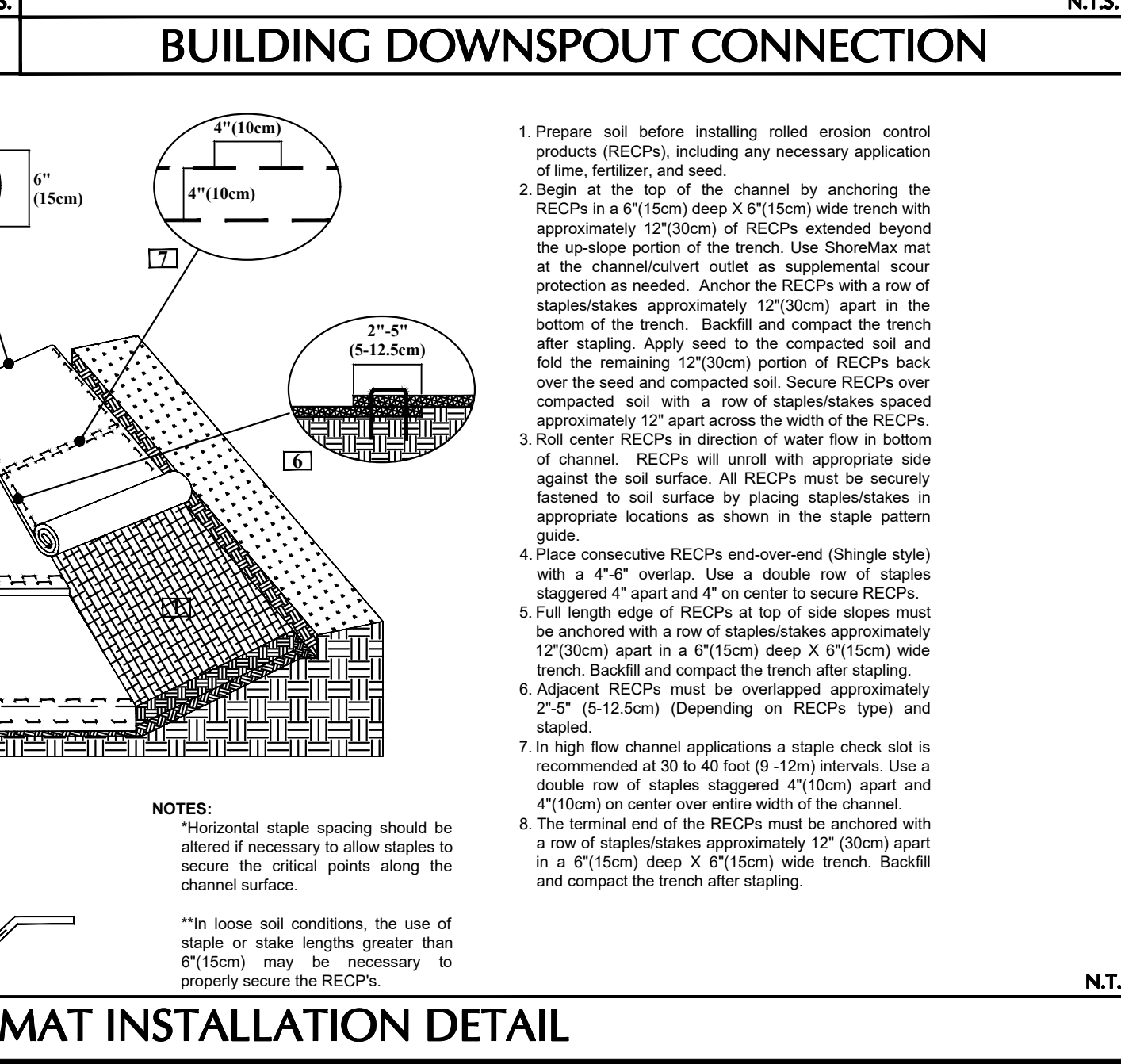
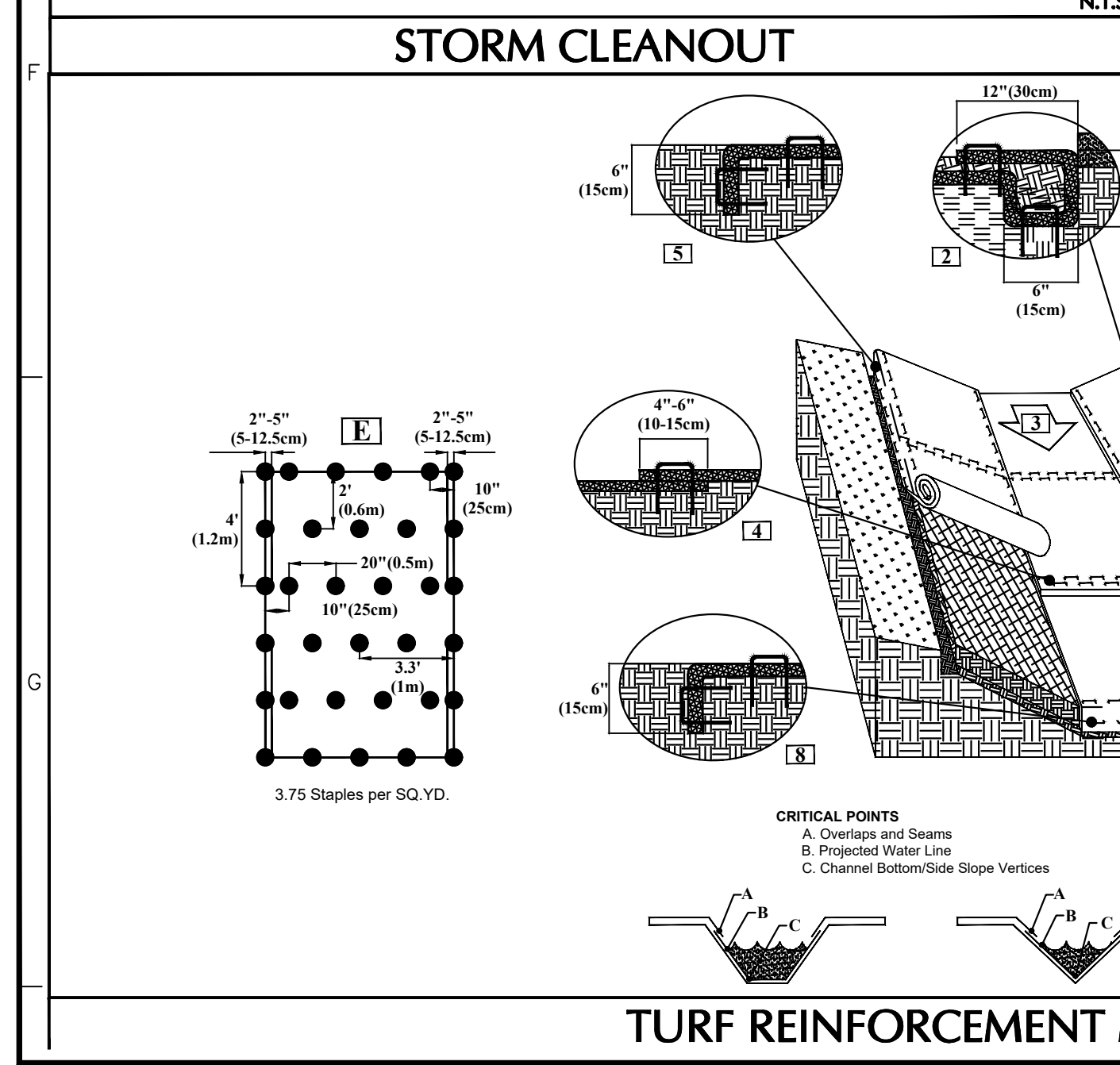
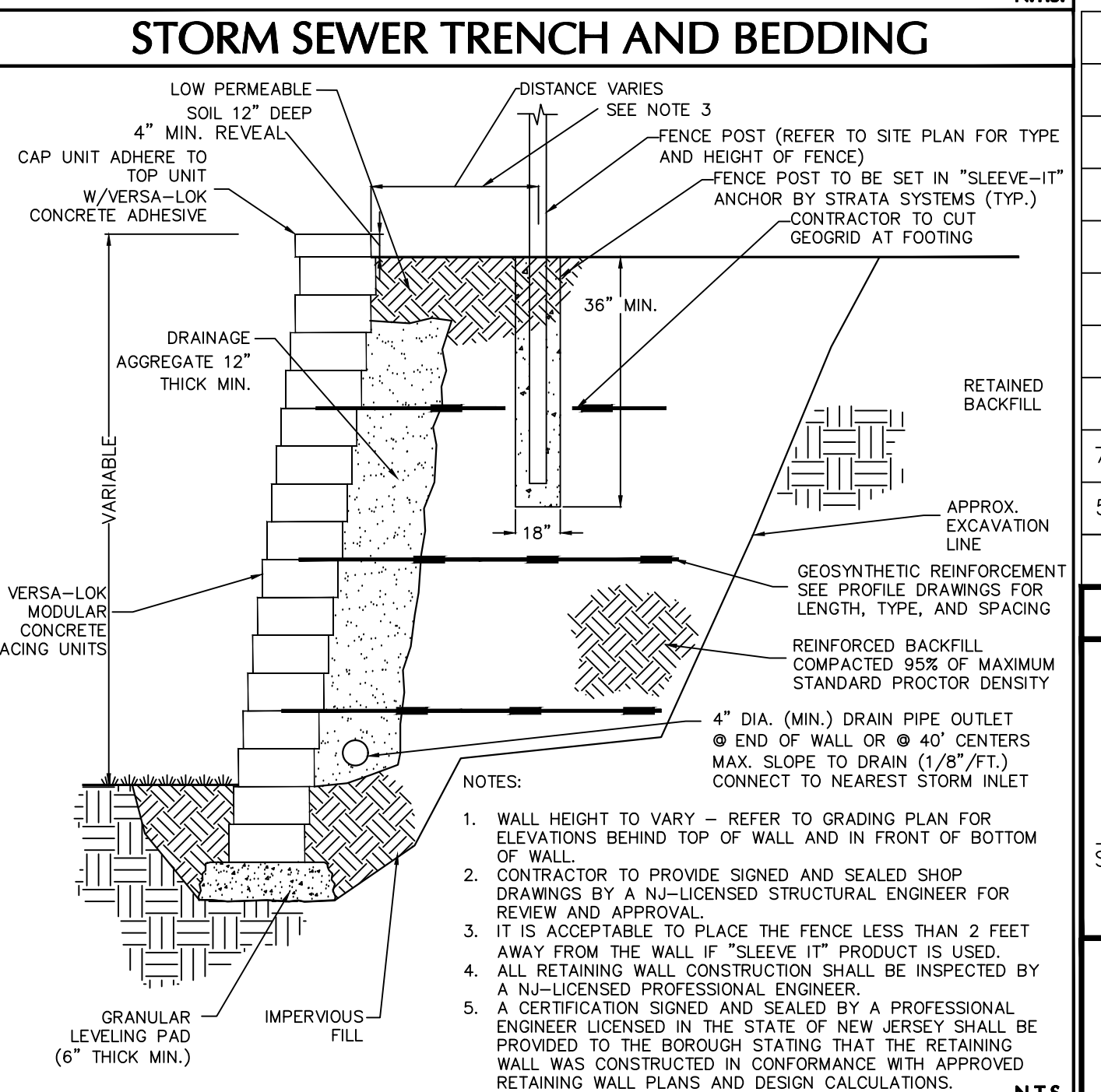
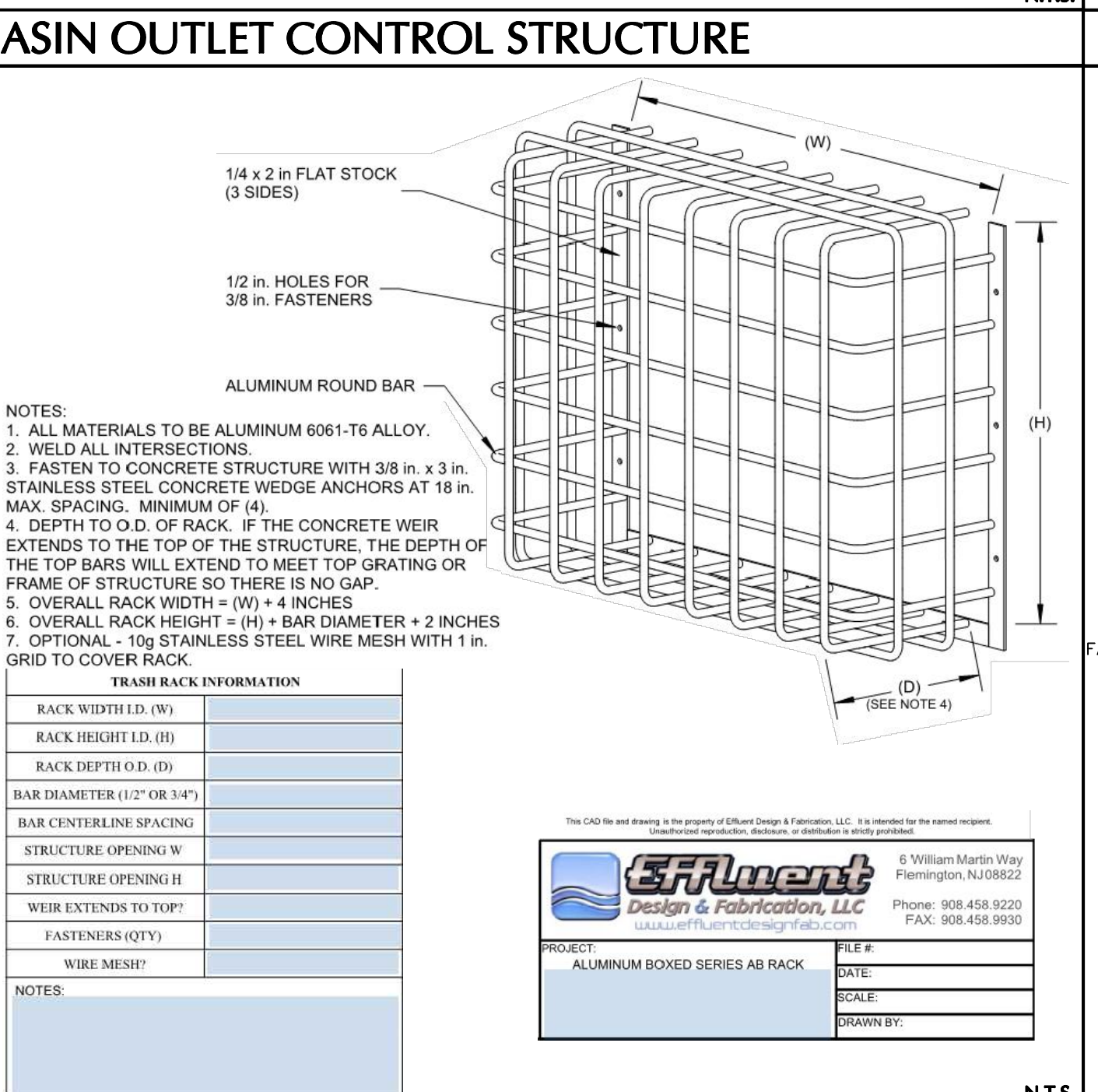
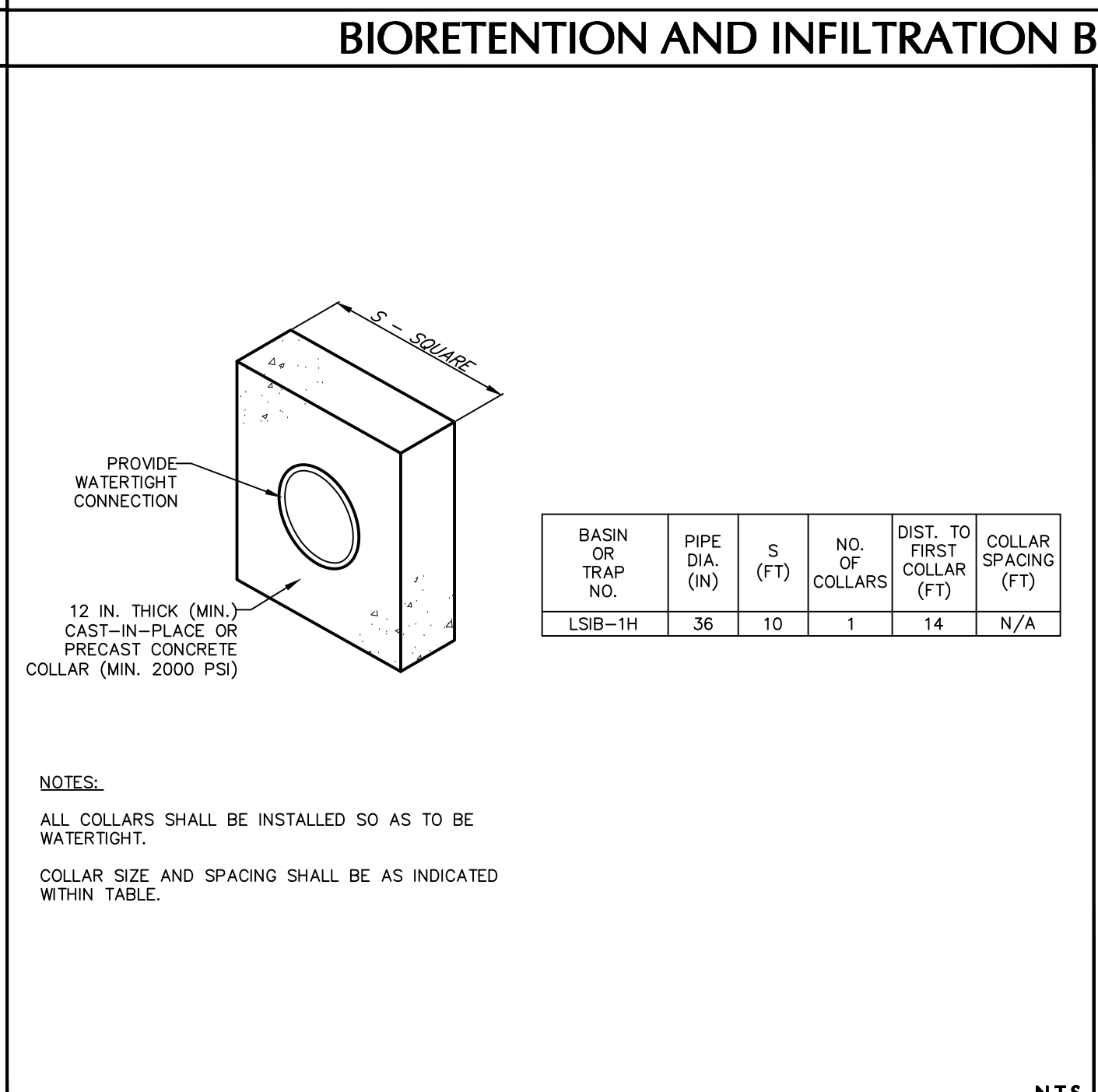
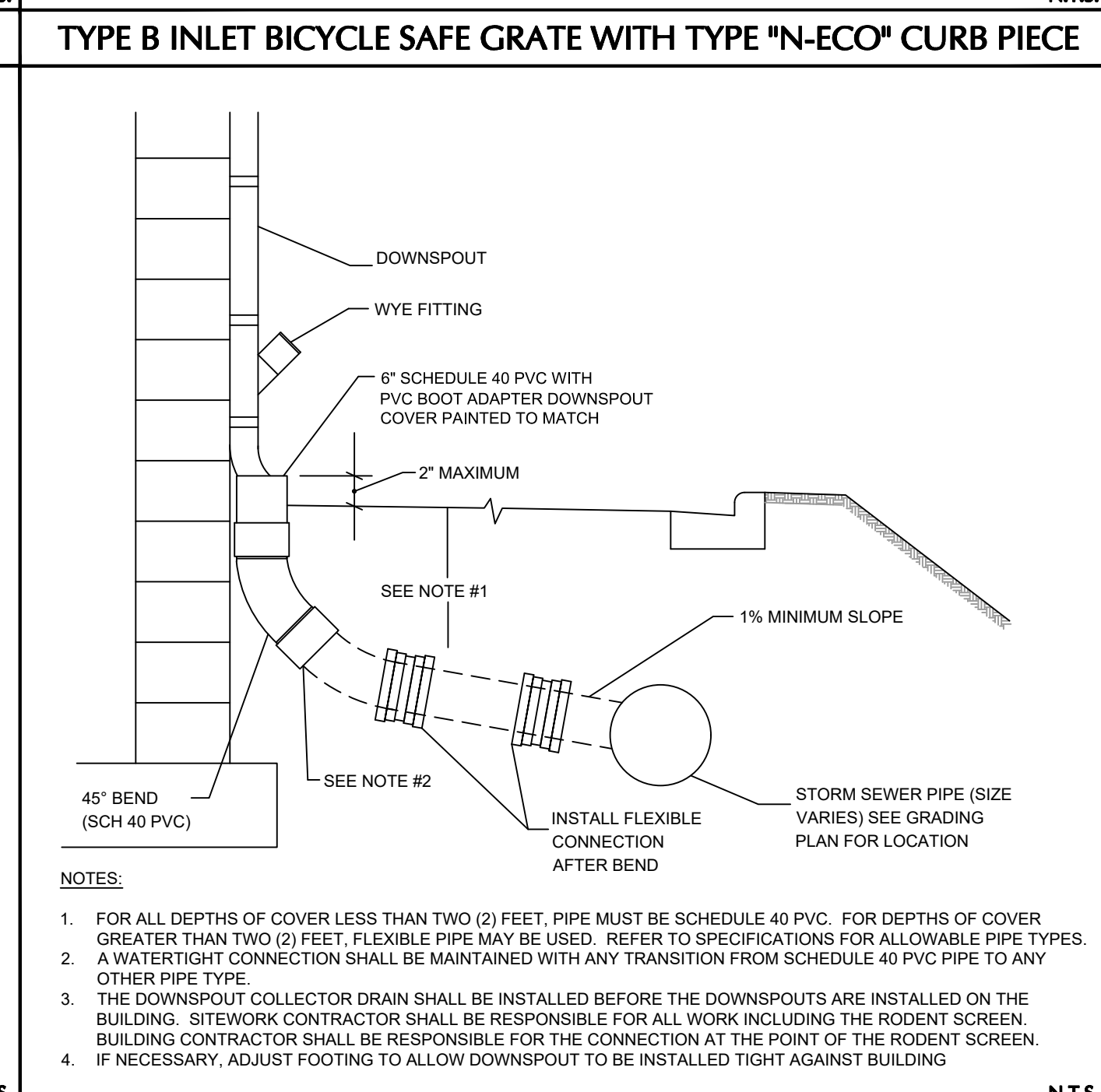
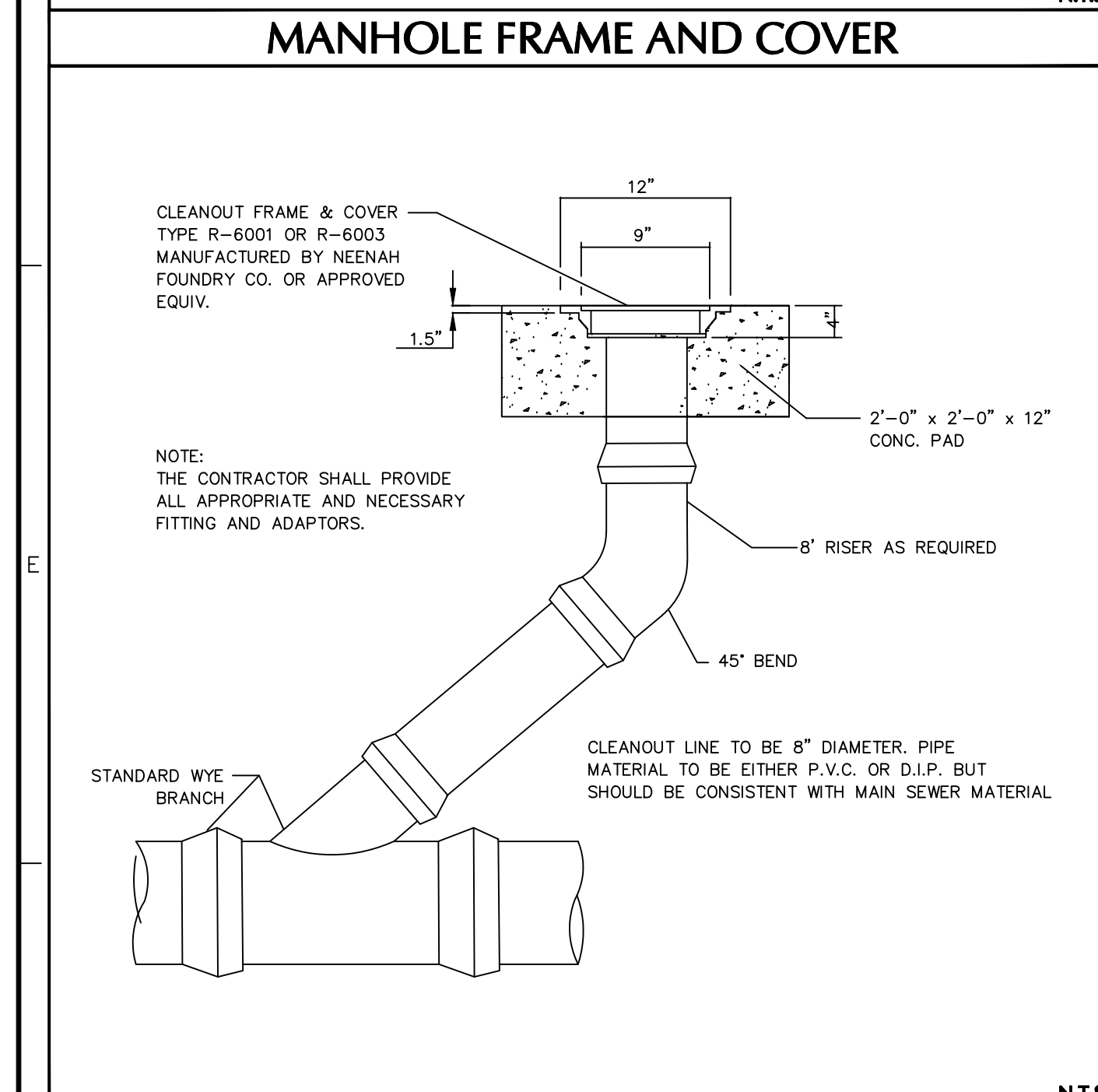
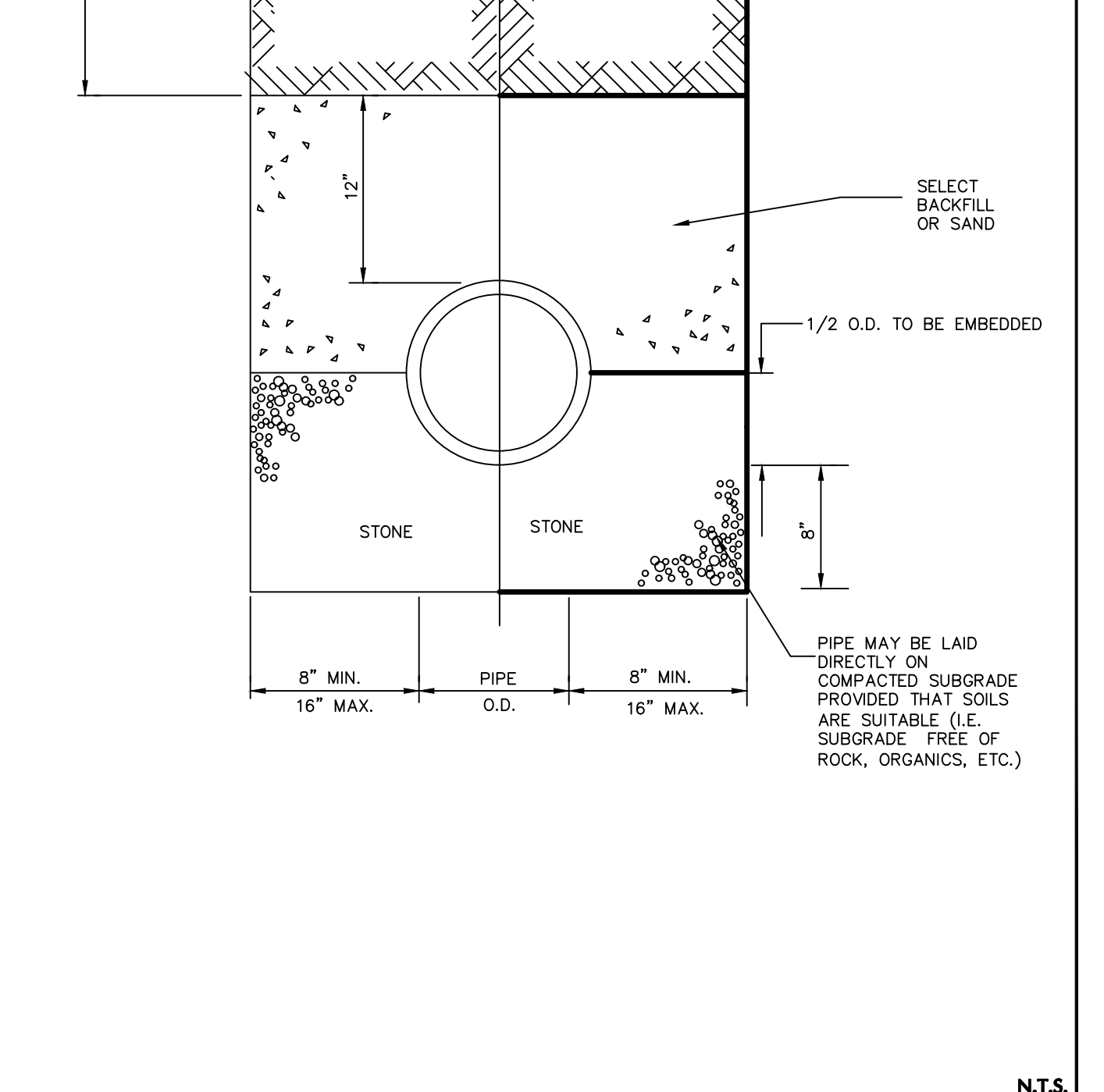
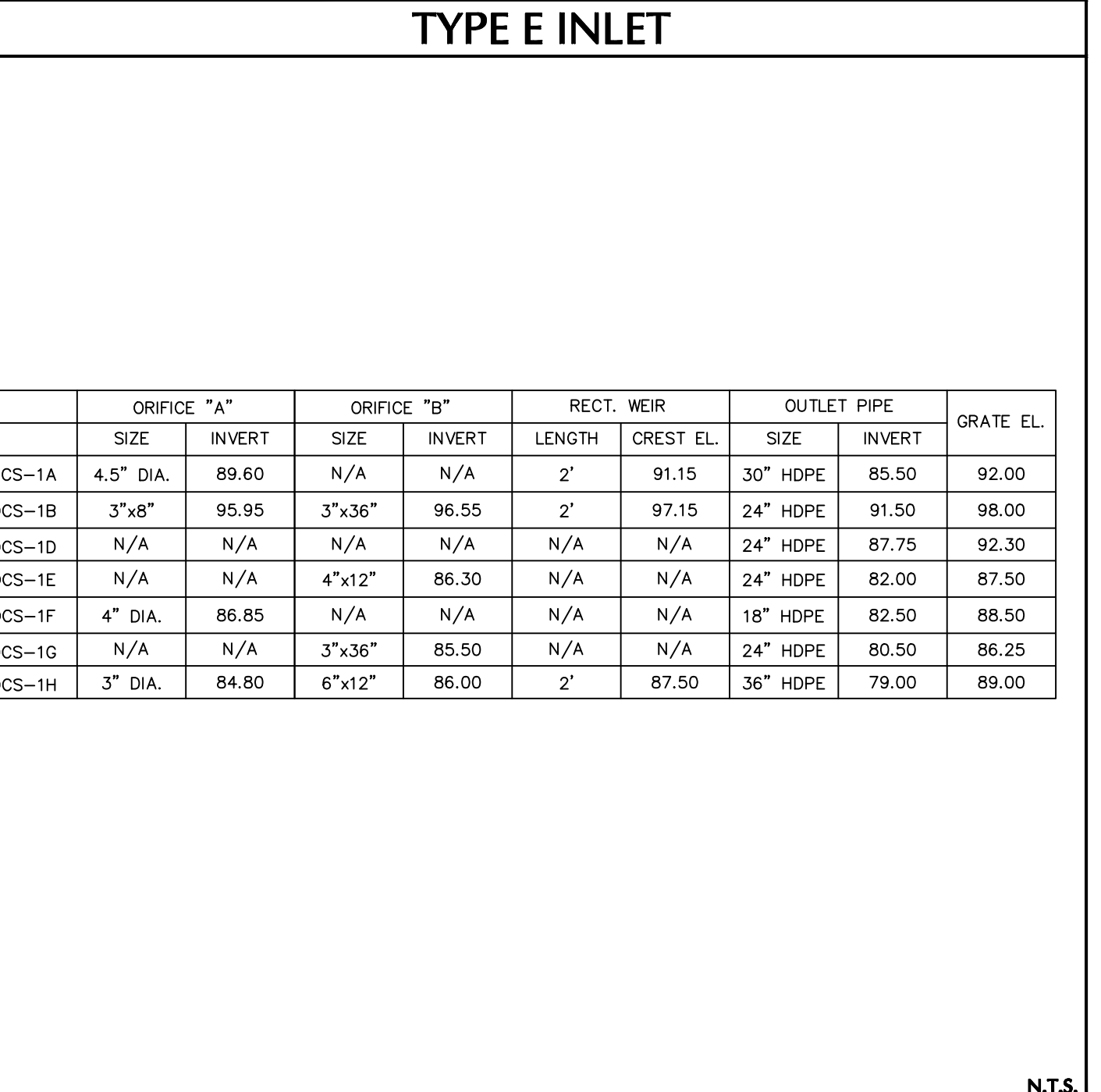
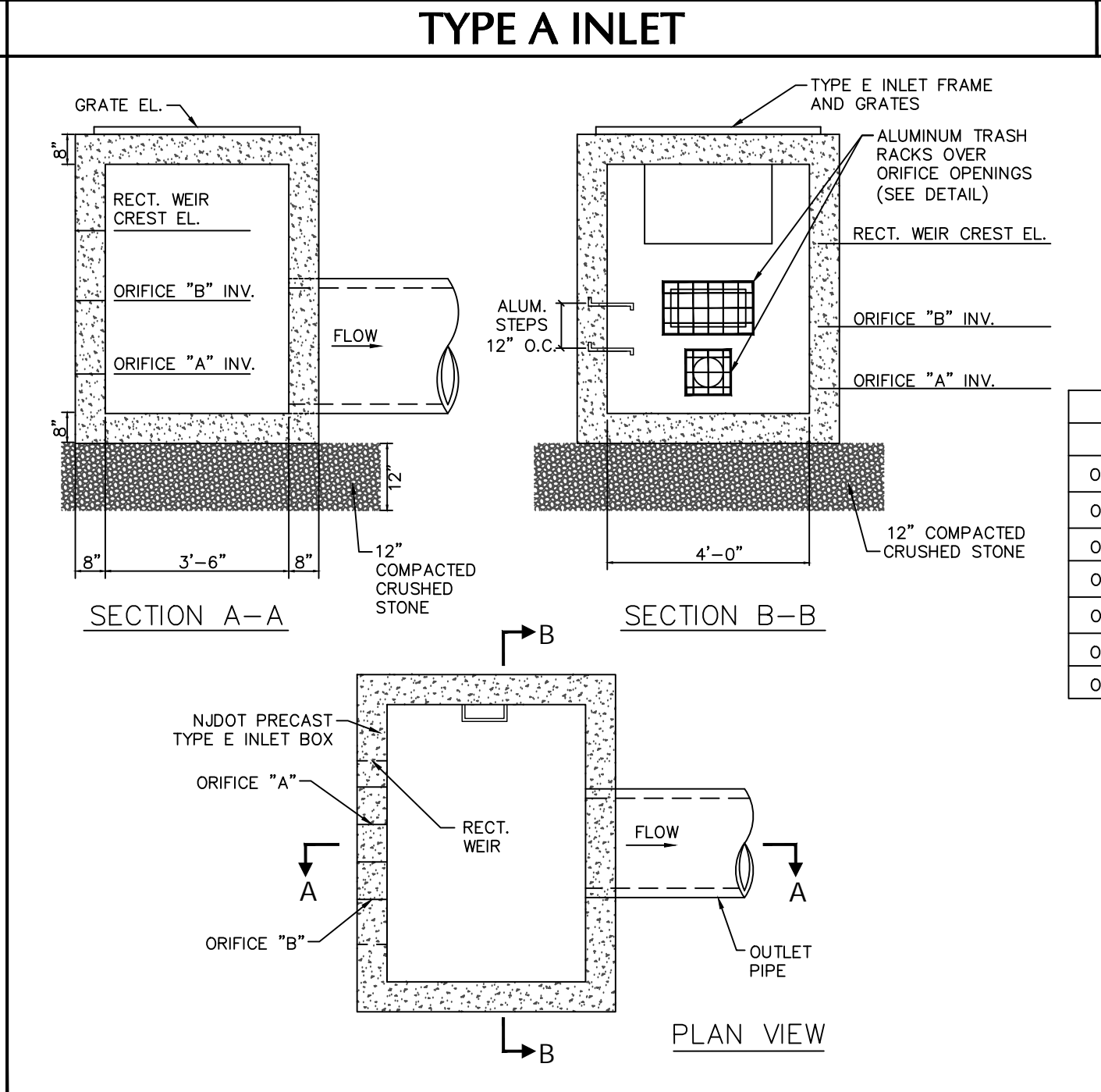
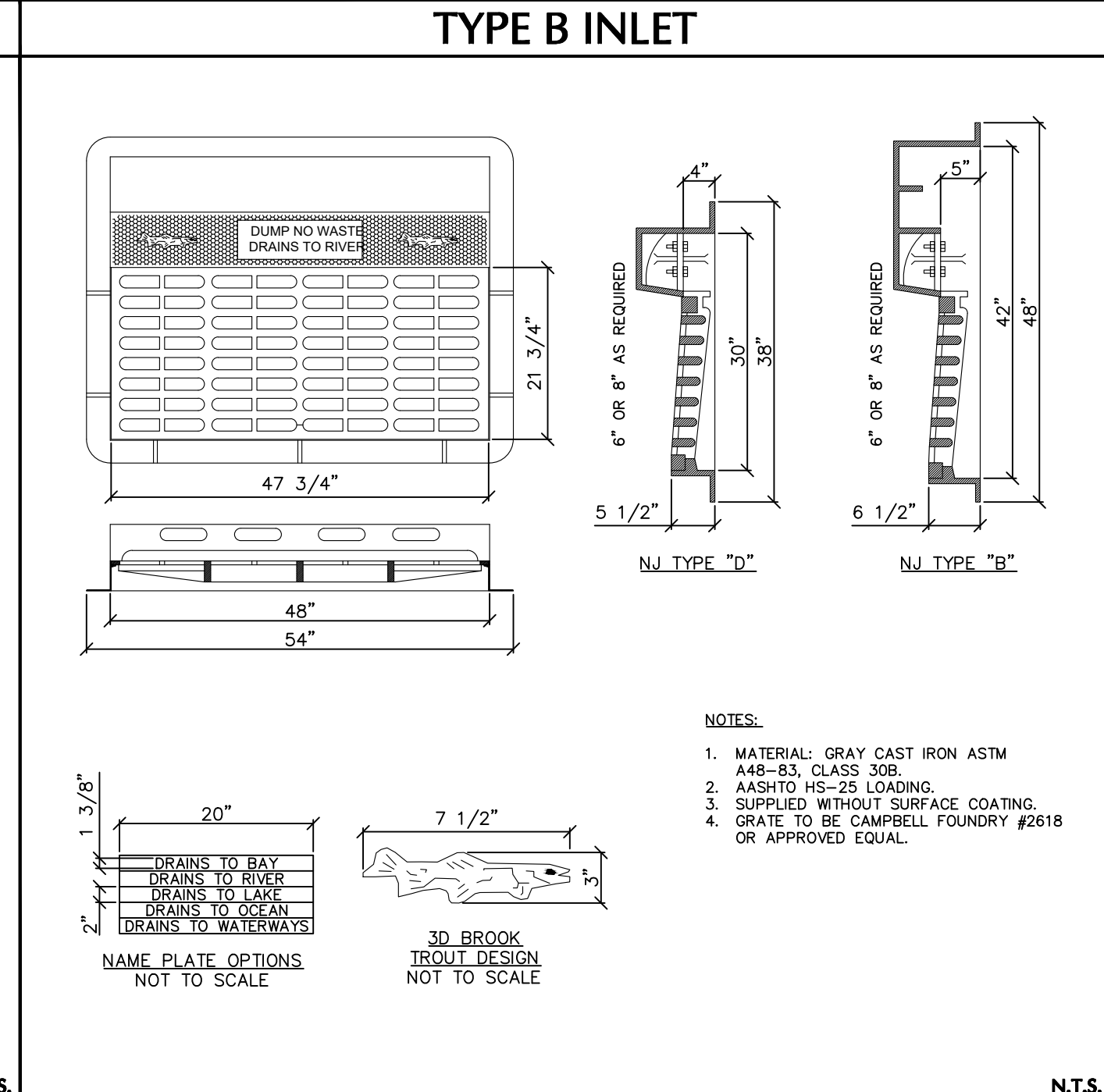
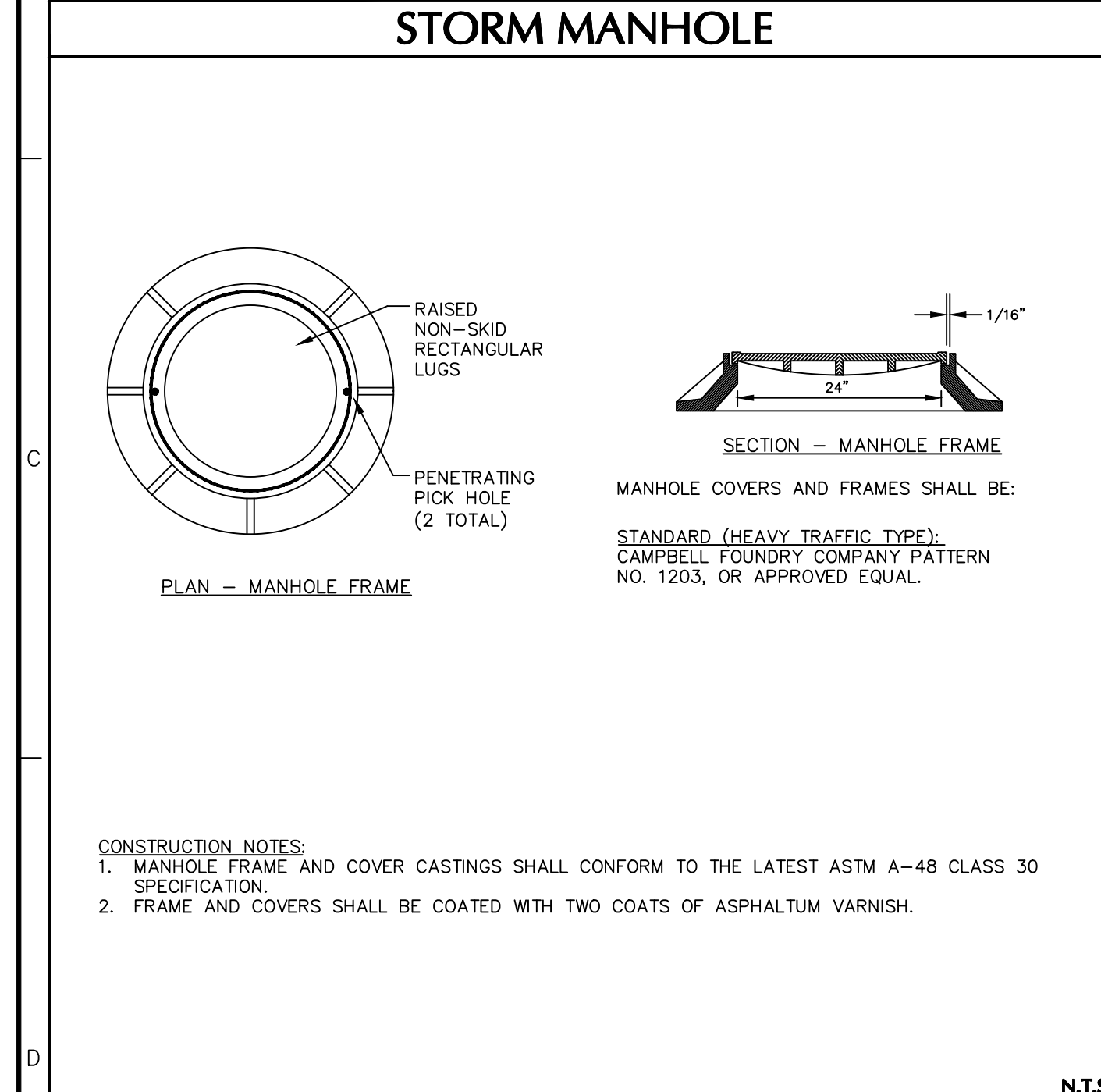
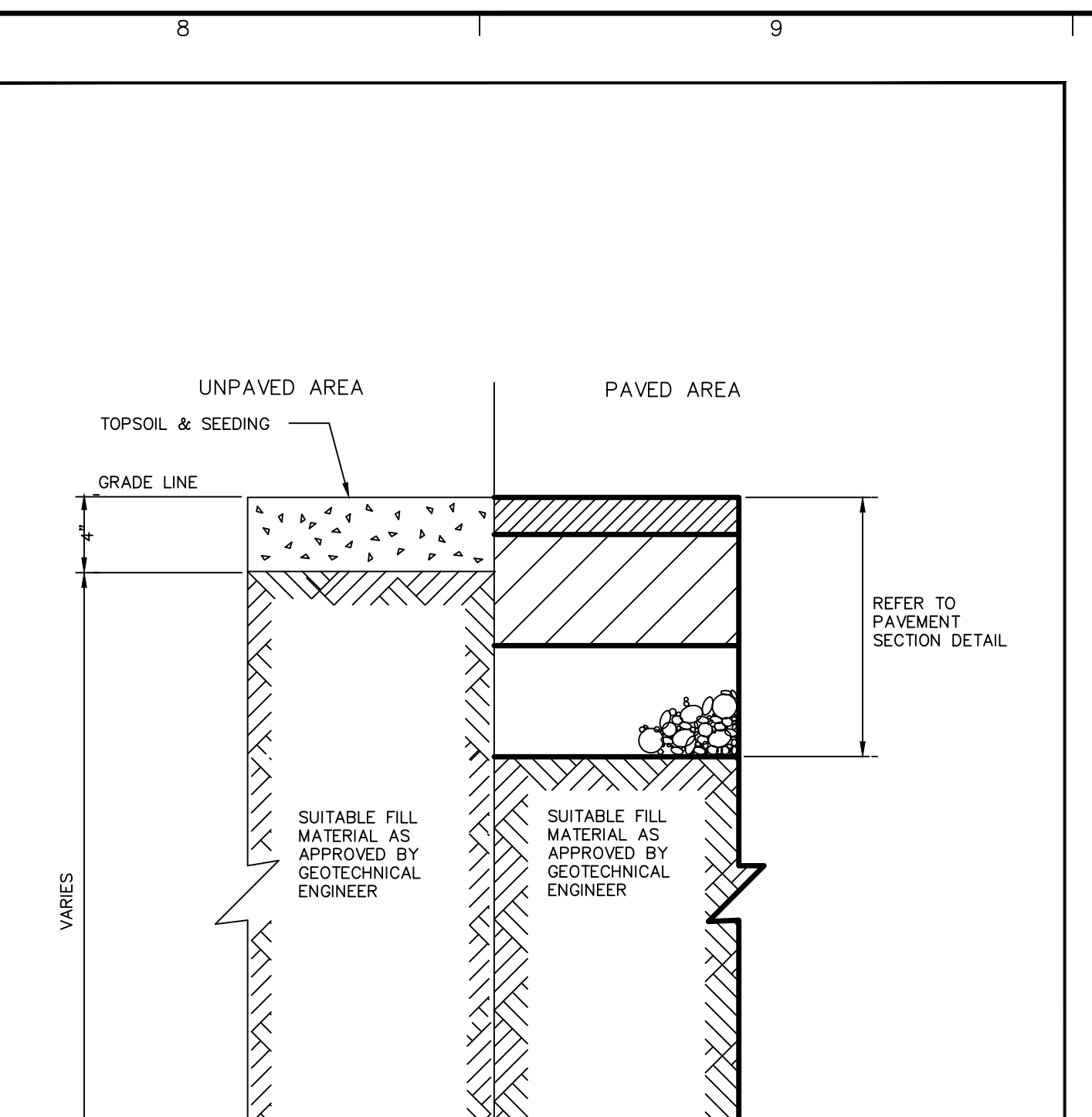
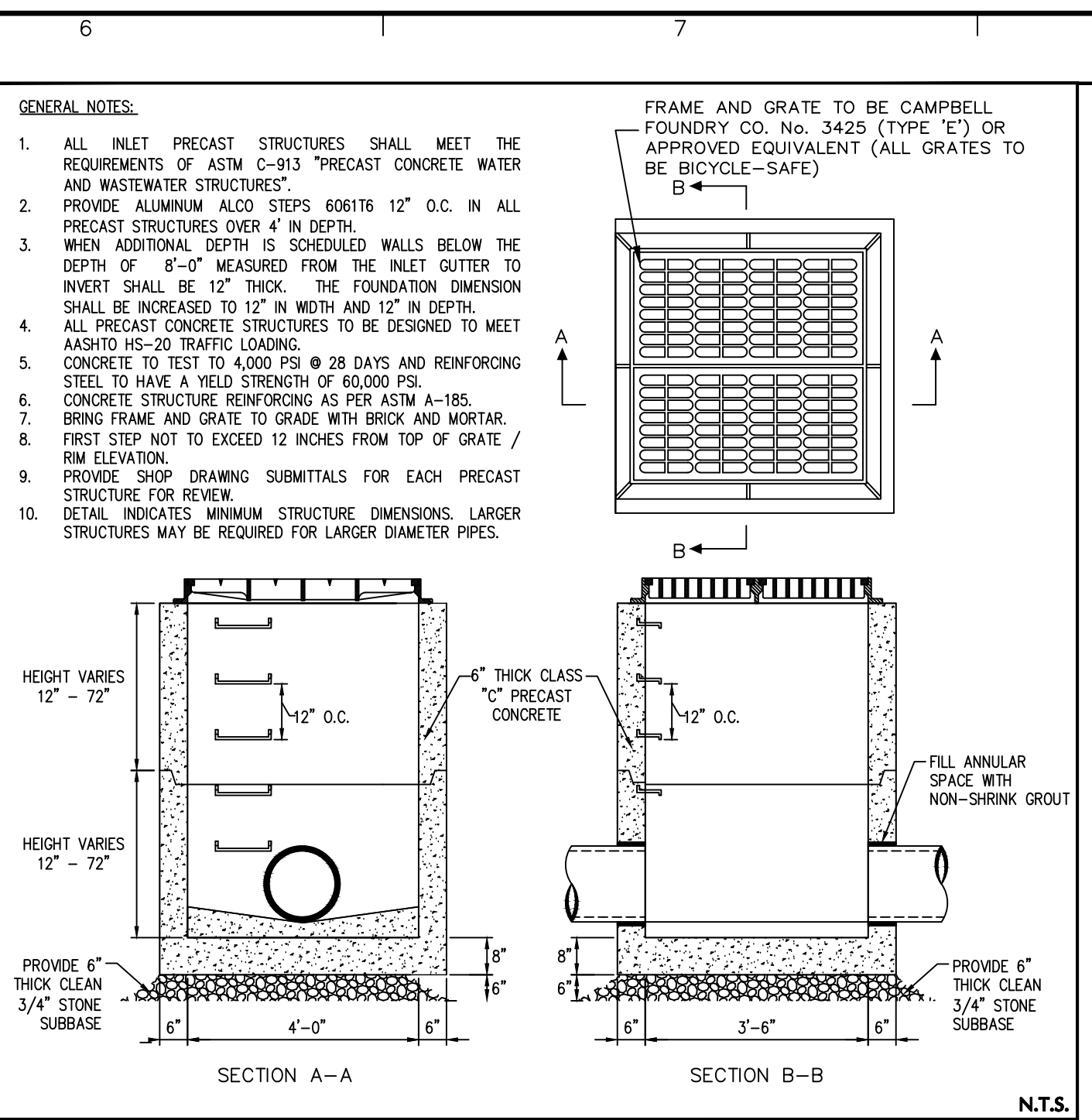
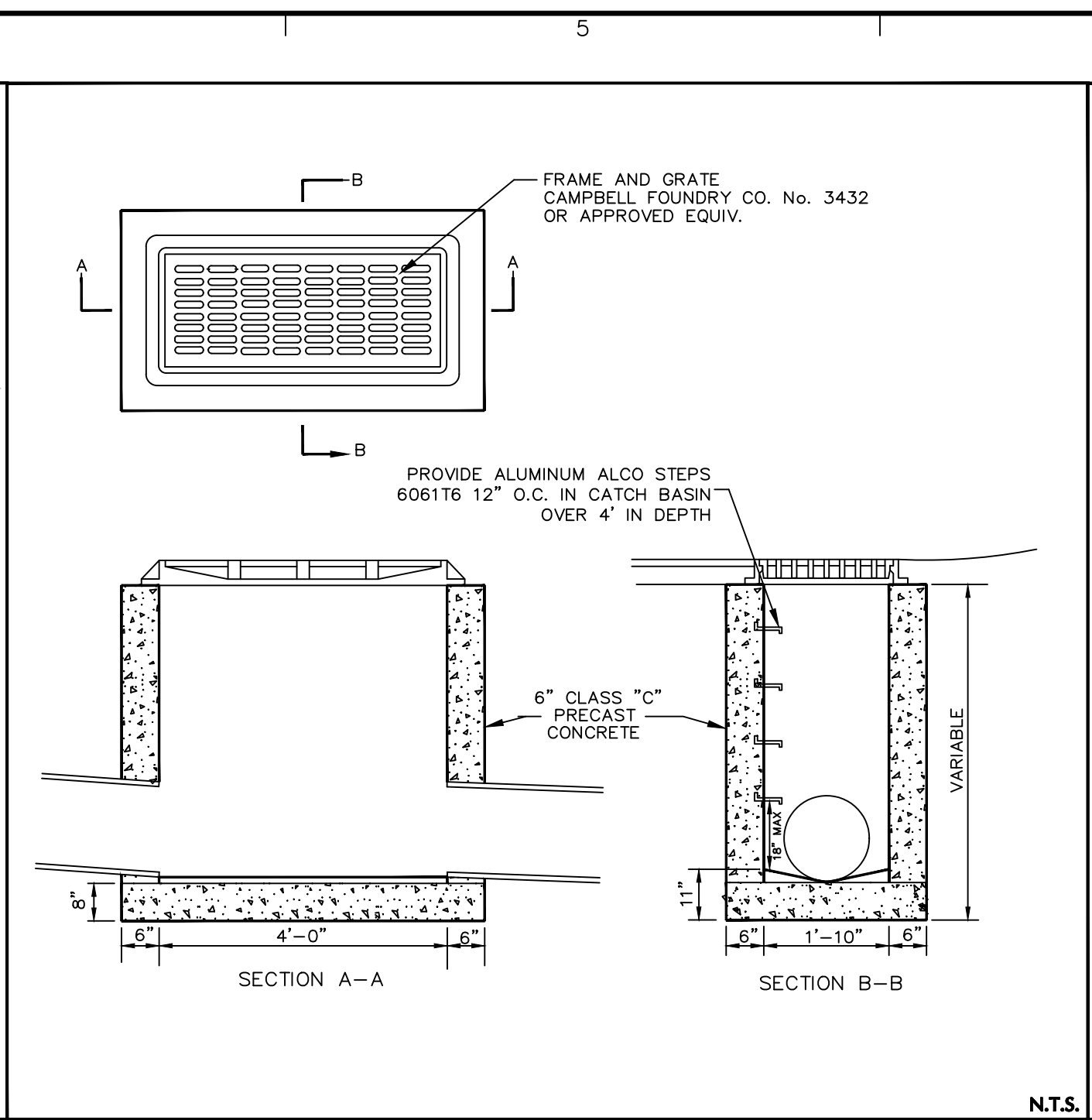
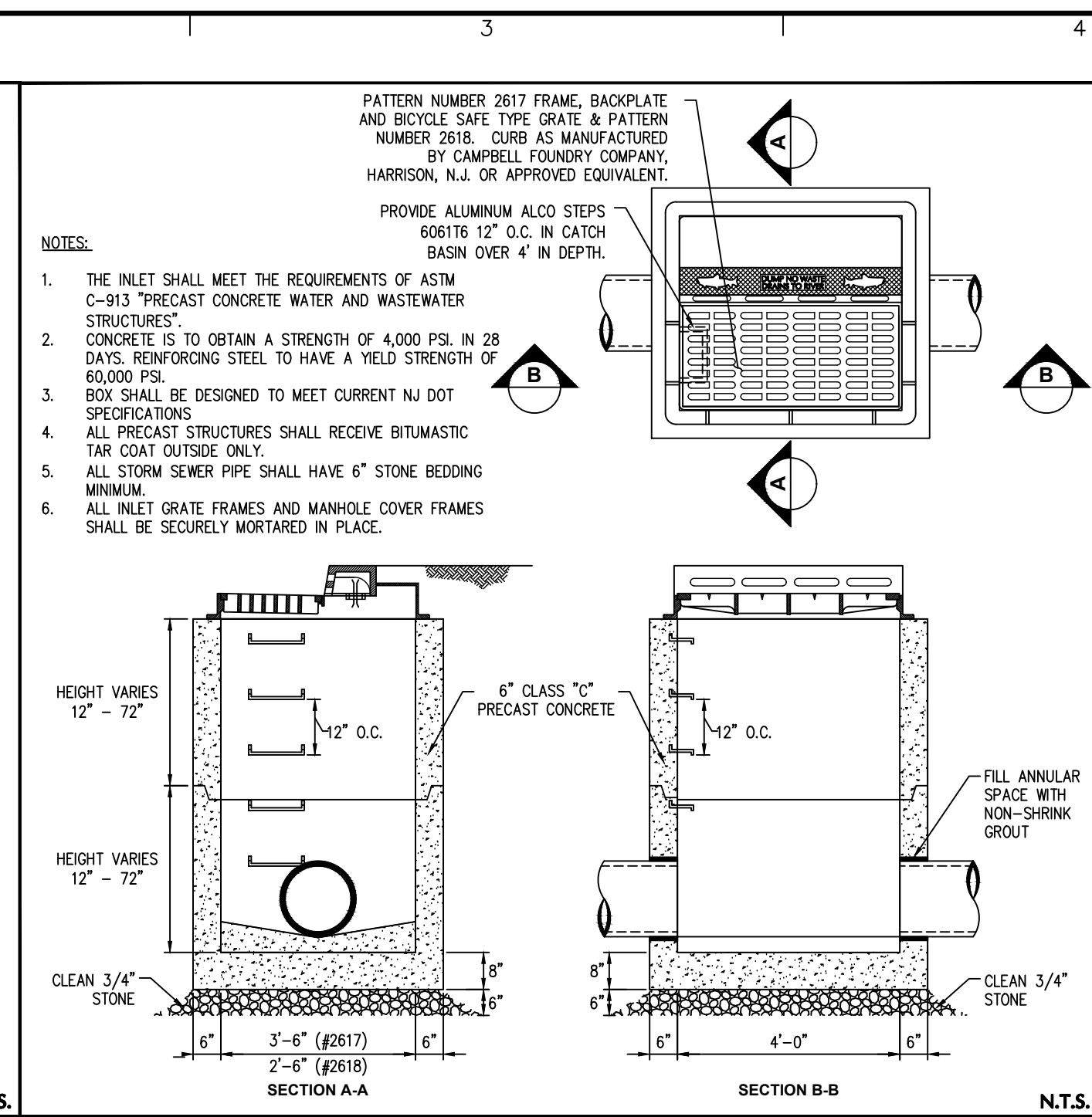
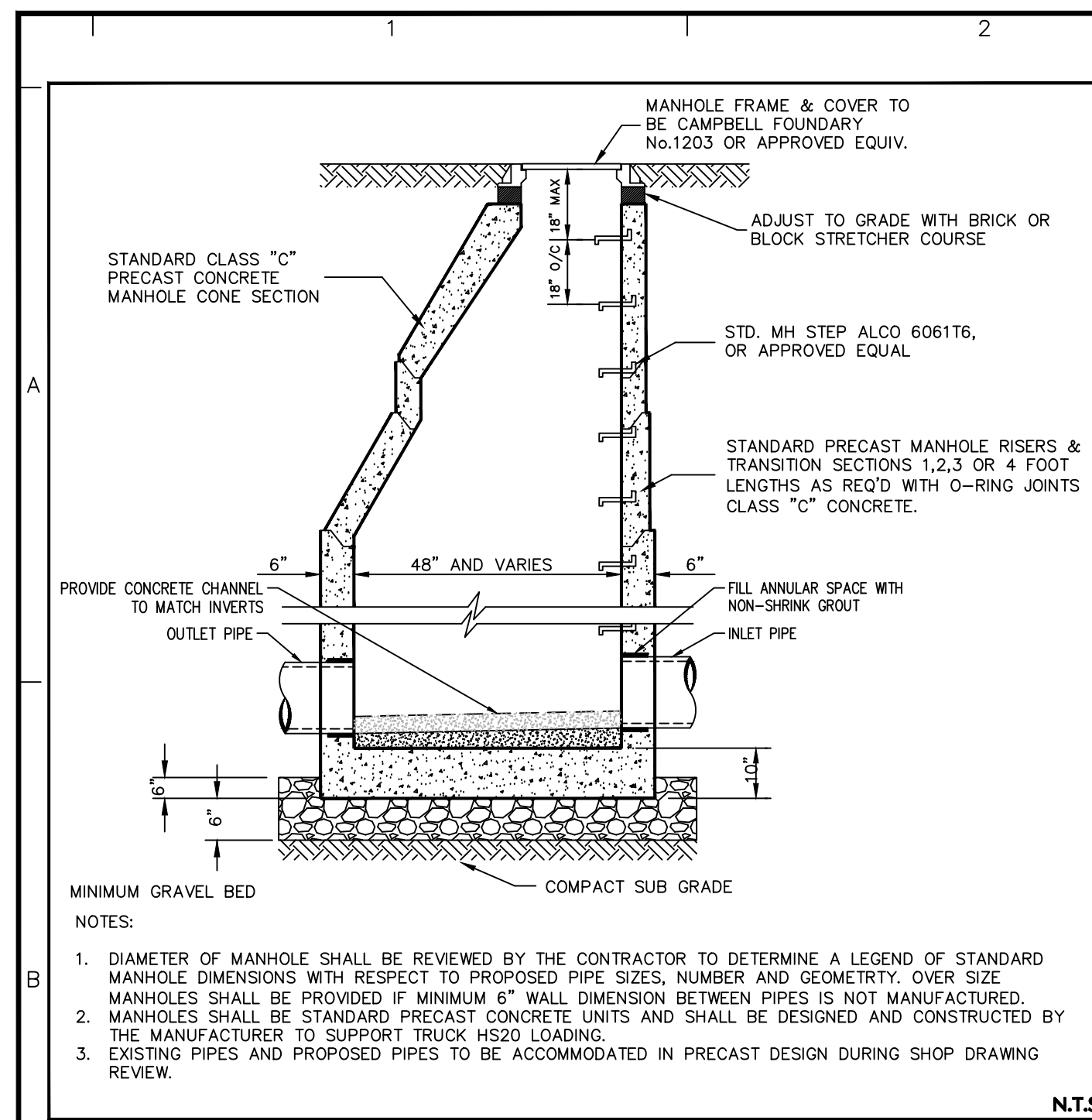

LANGAN

Project No. 100775002

Date	Description	No.
5/3/24	REVISED FOR SUBMISSION TO NEPTUNE	3
7/28/23	REVISED PER NJDOT, NJDEP, & FIRST ENERGY COMMENTS	2
5/10/23	REVISED RETAIL LAYOUT & PER NJDOT COMMENTS	1

REVISIONS

5/3/2024

DATE SIGNED

JOHN COTE

PROFESSIONAL ENGINEER NJ Lic. No. 24GE03705800

LANGAN

Langan Engineering and Environmental Services, LLC

300 Kimball Drive Parsippany, NJ 07054

T: 973.560.4900 F: 973.560.4901 www.langan.com
NJ Certificate of Authorization No. 24G24796640

Project

3501 STATE ROUTE 66 REDEVELOPMENT

BLOCK No. 3903, LOT No. 12 & 13 NEPTUNE TOWNSHIP

MONMOUTH COUNTY NEW JERSEY

Drawing Title

DRAINAGE DETAILS

Project No. 100775002 Drawing No. CG501

Date AUGUST 26, 2022

Drawn By TEG

Checked By MV

Sheet 30 of 48

© 2021 Langan

